



# SERVICE PARTS LIST

**BULLETIN NO.**  
**54-05-0827**

SPECIFY CATALOG NO. AND SERIAL NO. WHEN ORDERING PARTS		REVISED BULLETIN	DATE
<b>Variable Temperature HEAT GUN with LCD Display</b>		54-05-0826	Apr. 2023
<b>CATALOG NO.</b>	<b>8988-20</b>	<b>SERIAL NUMBER</b>	<b>199C</b>
WIRING INSTRUCTION			

**EXAMPLE:**  
Component Parts (Small #) Are Included  
When Ordering The Assembly (Large #).

★ = Part number change from  
previous service parts list.

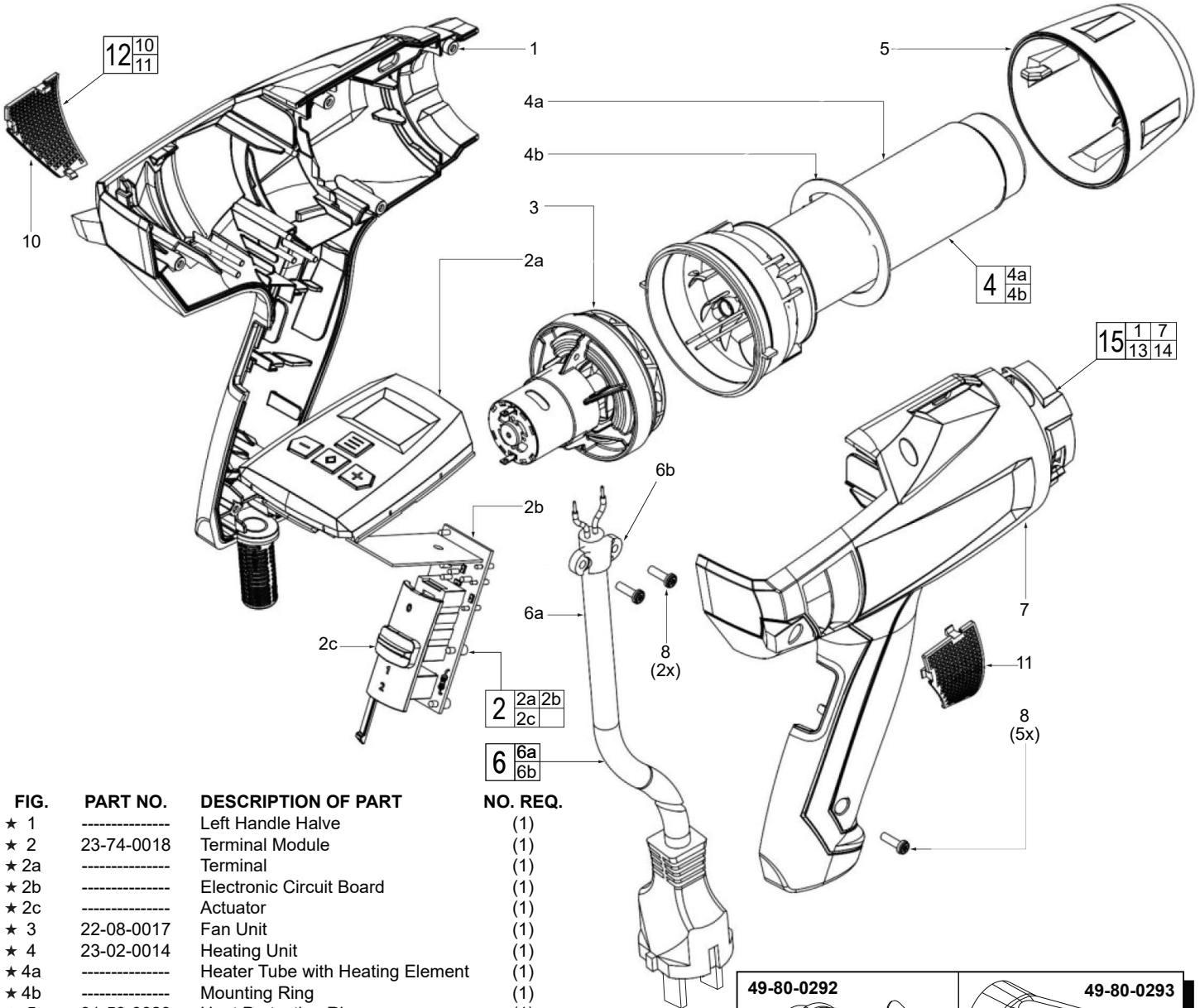
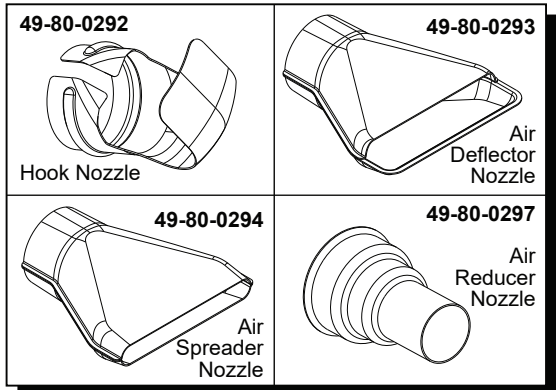

FIG.	PART NO.	DESCRIPTION OF PART	NO. REQ.
★ 1	-----	Left Handle Halve	(1)
★ 2	23-74-0018	Terminal Module	(1)
★ 2a	-----	Terminal	(1)
★ 2b	-----	Electronic Circuit Board	(1)
★ 2c	-----	Actuator	(1)
★ 3	22-08-0017	Fan Unit	(1)
★ 4	23-02-0014	Heating Unit	(1)
★ 4a	-----	Heater Tube with Heating Element	(1)
★ 4b	-----	Mounting Ring	(1)
★ 5	31-58-0023	Heat Protection Ring	(1)
★ 6	22-64-0052	Power Cord Service Kit	(1)
★ 6a	-----	Power Cord	(1)
★ 6b	-----	Strain Relief	(1)
★ 7	-----	Right Handle Halve	(1)
★ 8	06-95-0010	PT Screws	(7)
★ 9	12-20-0302	Service Nameplate (Not Shown)	(1)
★ 10	-----	Air Filter-Left	(1)
★ 11	-----	Air Filter-Right	(1)
★ 12	42-46-0017	Air Filter Kit	(1)
★ 13	10-20-9986	Warning Label (Not Shown)	(1)
★ 14	10-20-5938	Warning Label (Not Shown)	(1)
★ 15	31-44-0287	Handle Housing Kit	(1)



**FIG. 9, 13, 14**  
**NOTES**  
A clean, dry surface is essential for proper performance for any adhesive system. The area intended for application of any adhesive label or nameplate must be prepared by cleaning with isopropyl alcohol. The solvent is to be applied with a clean, lint free applicator and the surface allowed to dry before applying any label or nameplate.

**Cat. No. 49-80-0300**  
**Heat Gun Accessory Assortment**  
Includes the four accessories listed above.