



SERVICE PARTS LIST

BULLETIN NO.
54-06-2025

SPECIFY CATALOG NO. AND SERIAL NO. WHEN ORDERING PARTS			REVISED BULLETIN	DATE
M12™ LED UNDERHOOD LIGHT				Aug. 2017
CATALOG NO.	2125-20	STARTING SERIAL NO.	J03A	
			WIRING INSTRUCTION	

EXAMPLE:

00	0
----	---

 Component Parts (Small #)
 Are Included When Ordering
 The Assembly (Large #).

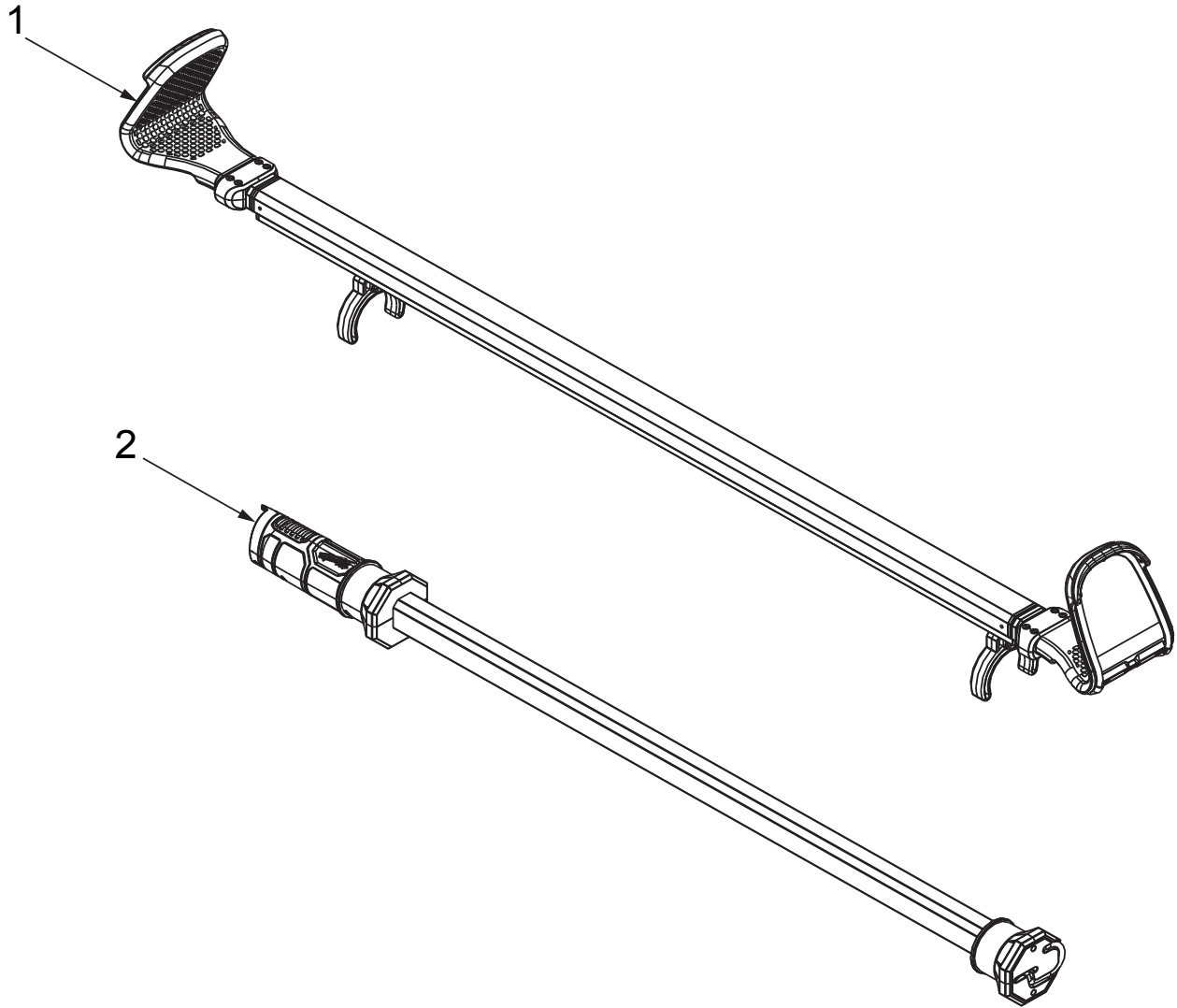

FIG.	PART NO.	DESCRIPTION OF PART	NO. REQ.
1	14-46-2150	Light Carrier Assembly	(1)
2	14-46-2155	Light Assembly	(1)

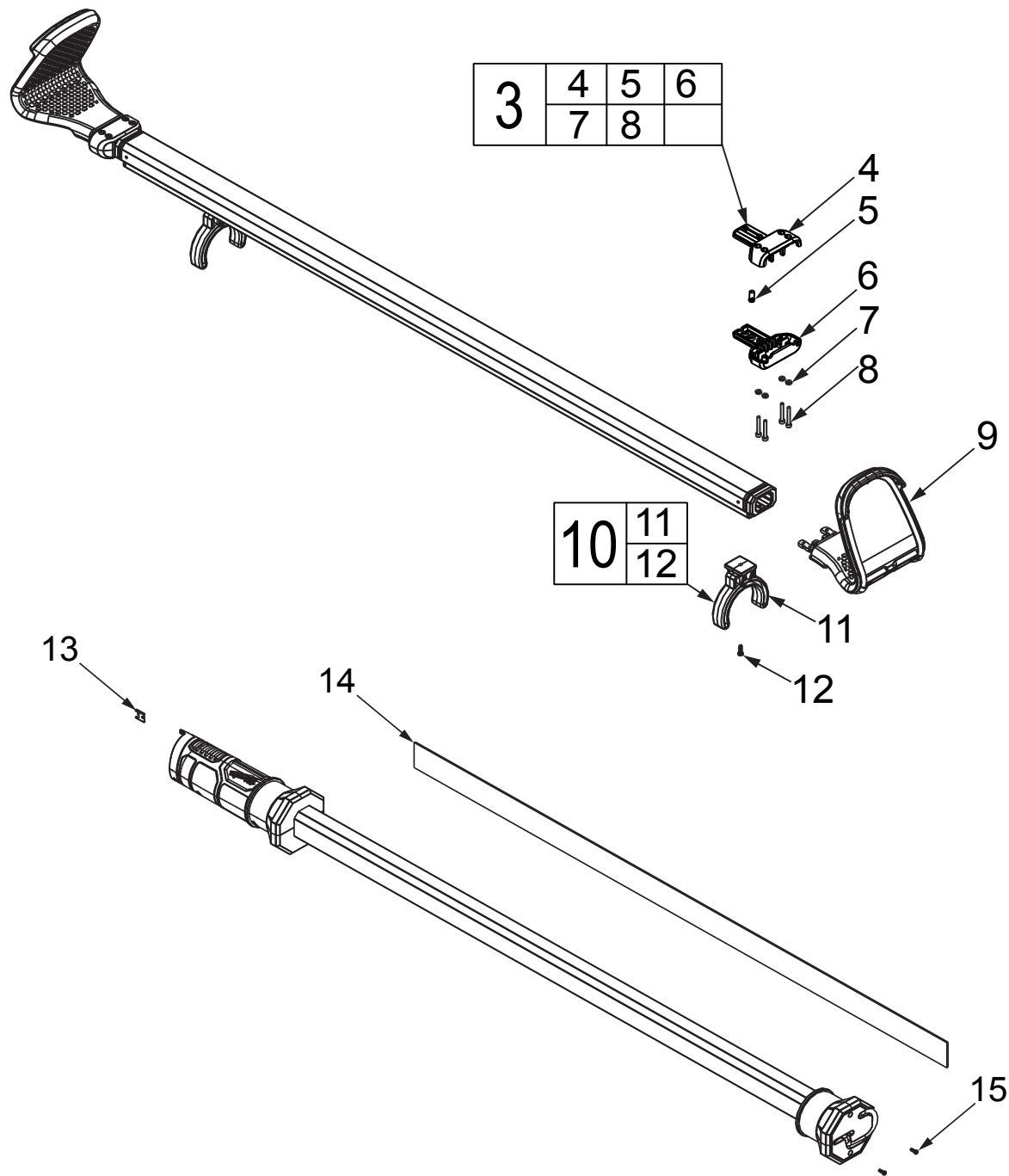

FIG.	PART NO.	DESCRIPTION OF PART	NO. REQ.
3	14-38-0045	Carrier Hook Connector Kit	(1)
4	-----	Connector Top	(1)
5	-----	Fixing Pin	(1)
6	-----	Connector Bottom	(1)
7	-----	Nut	(4)
8	-----	3 x 22 Hex Bolt	(4)
9	14-36-0025	Carrier Hook	(1)
10	42-70-0155	Fixing Hook with Screw	(1)
11	-----	Fixing Hook	(1)
12	-----	3 x 10 Screw	(1)
13	42-70-0058	Battery Clip	(1)
14	44-06-0145	Lens	(1)

FIG.	PART NO.	DESCRIPTION OF PART	NO. REQ.
15	05-88-0085	2.6 x 10 Screw	(2)
16	12-20-2165	Service Nameplate (Not Shown)	(1)

FIG. NOTES
 16 A clean, dry surface is essential for proper performance for any adhesive system. The area intended for application of any adhesive label or nameplate must be prepared by cleaning with isopropyl alcohol. The solvent is to be applied with a clean, lint free applicator and the surface allowed to dry before applying the label or nameplate.