

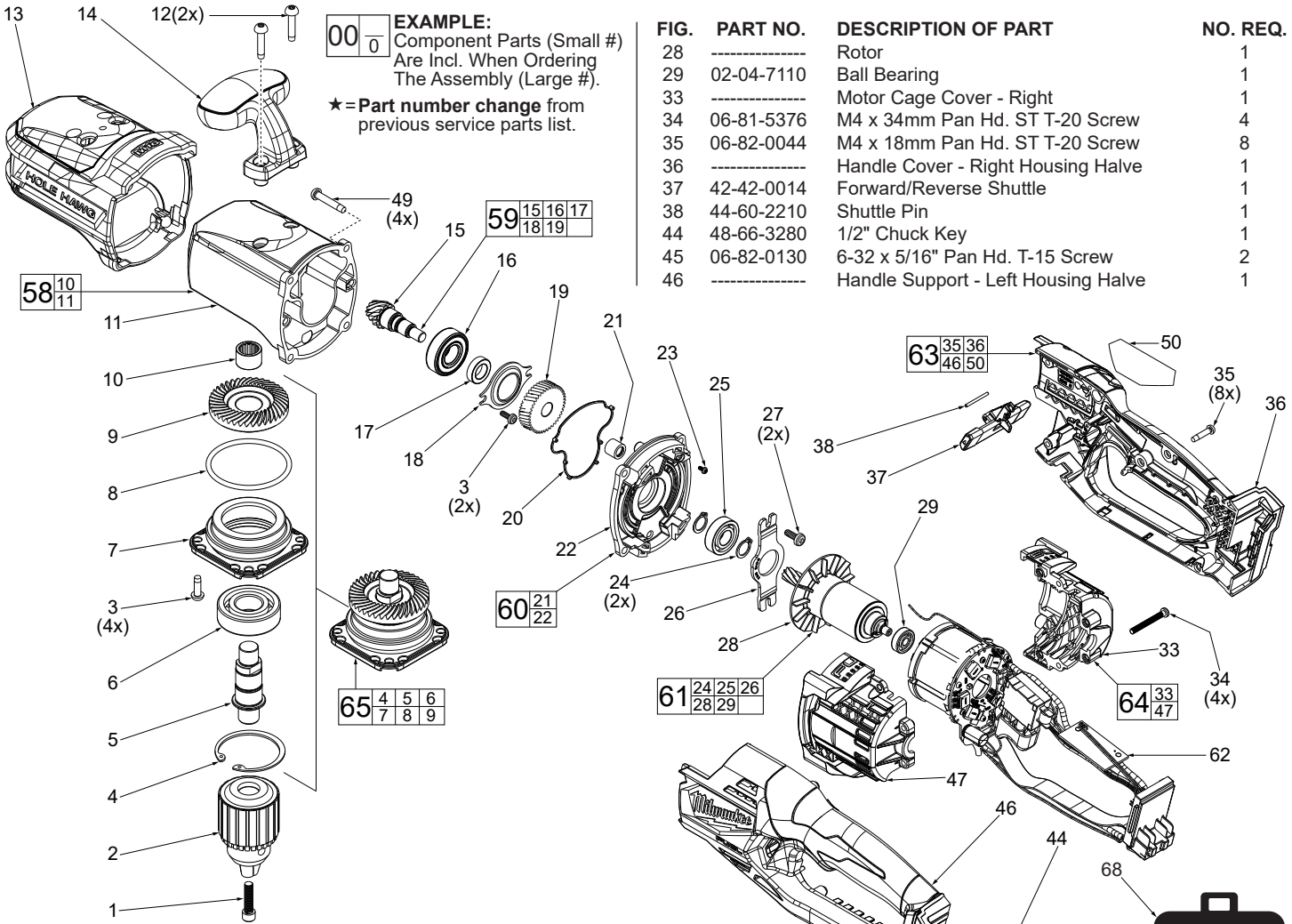

SERVICE PARTS LIST

BULLETIN NO.
54-10-2801

SPECIFY CATALOG NO. AND SERIAL NO. WHEN ORDERING PARTS		REVISED BULLETIN 54-10-2801	DATE Sept. 2023
M18 FUEL™ 1/2" Hole-Hawg®		WIRING INSTRUCTION SEE PAGE 3	
CATALOG NO.	2807-20	STARTING SERIAL NO.	L24B



EXAMPLE:
Component Parts (Small #)
Are Incl. When Ordering
The Assembly (Large #).
★ = Part number change from
previous service parts list.

FIG.	PART NO.	DESCRIPTION OF PART	NO. REQ.
28	-----	Rotor	1
29	02-04-7110	Ball Bearing	1
33	-----	Motor Cage Cover - Right	1
34	06-81-5376	M4 x 34mm Pan Hd. ST T-20 Screw	4
35	06-82-0044	M4 x 18mm Pan Hd. ST T-20 Screw	8
36	-----	Handle Cover - Right Housing Halve	1
37	42-42-0014	Forward/Reverse Shuttle	1
38	44-60-2210	Shuttle Pin	1
44	48-66-3280	1/2" Chuck Key	1
45	06-82-0130	6-32 x 5/16" Pan Hd. T-15 Screw	2
46	-----	Handle Support - Left Housing Halve	1

FIG.	PART NO.	DESCRIPTION OF PART	NO. REQ.
1	06-75-3150	1/4-20 x 1" Left Hand Thread Chuck Screw	1
2	48-66-1381	1/2" Chuck	1
3	06-82-5411	10-24 x .625" Pan Hd. Tapt. T-25 Screw	6
4	-----	Retaining Ring	1
5	-----	Output Shaft	1
6	-----	Ball Bearing	1
7	-----	Output Mount Hub	1
8	34-40-2700	O-Ring	1
9	-----	Bevel Gear	1
10	-----	Needle Bearing	1
11	-----	Gearcase	1
12	05-88-9915	M5 x 25mm DG Pan Hd. T-25 Screw	1
13	45-12-2735	Insulated Boot	1
14	31-44-2717	Top Handle	1
15	-----	Bevel Pinion	1
16	02-04-1537	Ball Bearing	1
17	-----	Bushing	1
18	-----	Retaining Plate	1
19	-----	1st Helical Gear	1
20	43-44-0115	Gasket Seal	1
21	02-50-5381	Needle Bearing	1
22	-----	Diaphragm	1
23	06-82-0165	M2.5 x 0.45 Pan Hd. Tapt. T-8 Screw	1
24	34-60-0610	Snap Ring	2
25	02-04-1204	Ball Bearing	1
26	-----	Pinion Bearing Plate	1
27	06-82-5324	10-24 x 12mm Pan Hd. Taptite T-25 Screw	2

FIG.	PART NO.	DESCRIPTION OF PART	NO. REQ.
47	-----	Motor Cage Support - Left	1
49	05-81-2005	M5 x 28mm Pan Hd. ST T-25 Screw	4
50	12-20-8595	Service Nameplate	1
58	14-30-2740	Gearcase Assembly	1
★59	32-40-0111	Intermediate Gear Assembly	1
60	14-13-0030	Diaphragm Assembly	1
61	16-01-6015	Rotor Assembly	1
62	14-20-7010	Electronics Assembly	1
63	31-44-5393	Housing Assembly	1
64	23-16-1055	Motor Cage Assembly	1
★65	14-29-0073	Output Assembly	1
66	43-72-0012	Chuck Key Holder Assembly	1
68	48-55-3565	FUEL™ Contractor Bag - Large	1

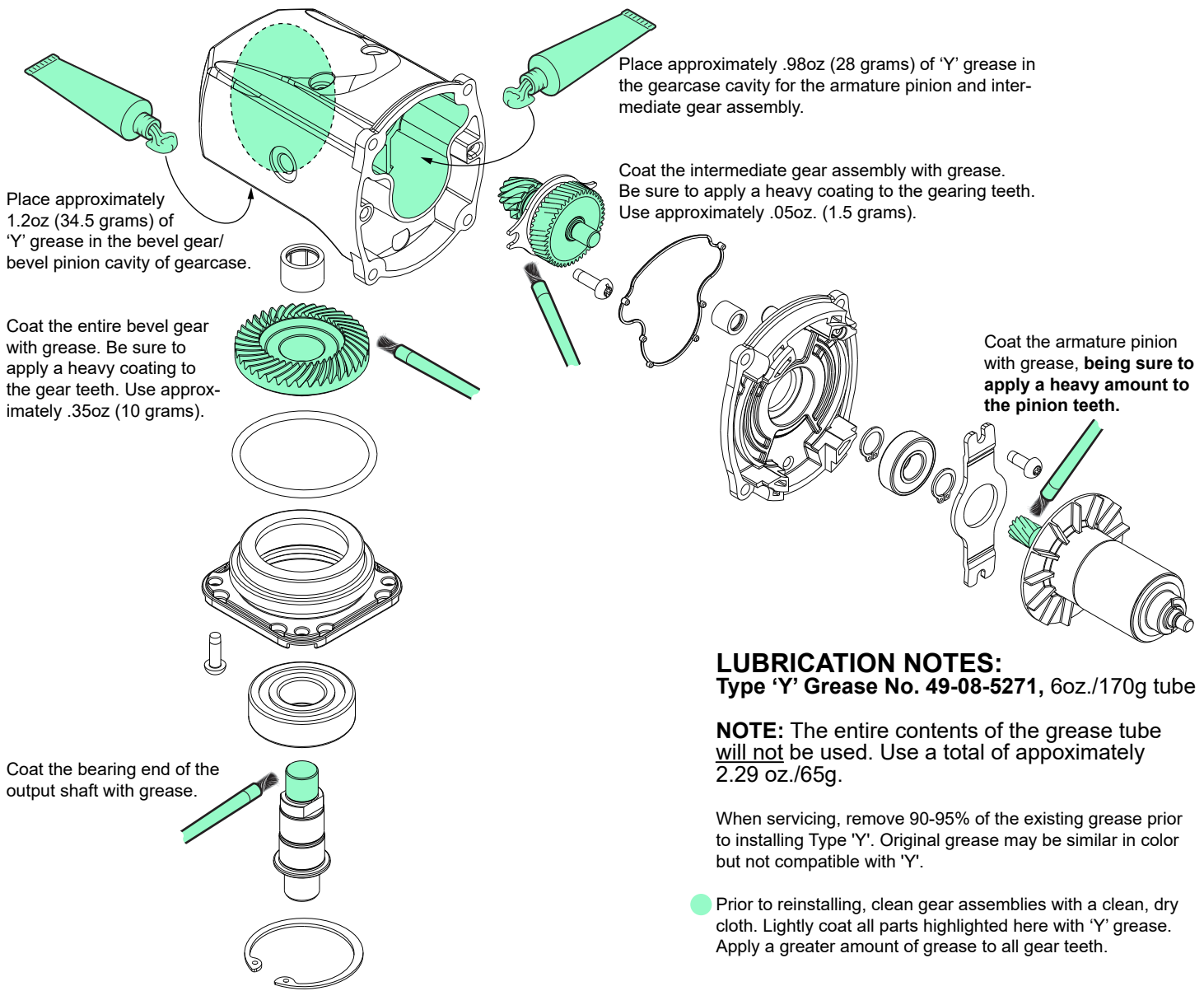

LUBRICATION NOTES:
 Type 'Y' Grease No. 49-08-5271, 6oz./170g tube

NOTE: The entire contents of the grease tube will not be used. Use a total of approximately 2.29 oz./65g.

When servicing, remove 90-95% of the existing grease prior to installing Type 'Y'. Original grease may be similar in color but not compatible with 'Y'.

● Prior to reinstalling, clean gear assemblies with a clean, dry cloth. Lightly coat all parts highlighted here with 'Y' grease. Apply a greater amount of grease to all gear teeth.

Chuck Tightening Fixture
 No. 61-40-1115

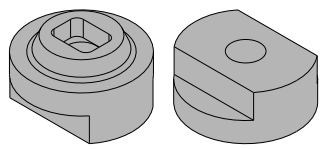

Place a 7/16" or 1/2" Hex Bit Socket in chuck (be sure that most of the hex shaft is inserted and that the shaft is in chuck squarely). Use chuck key to tighten at all three chuck hole positions! Place a torque wrench in socket and tighten to approximately 80-90 ft-lbs. (108.5-122 Nm). Install the chuck screw and torque to the value in chart.

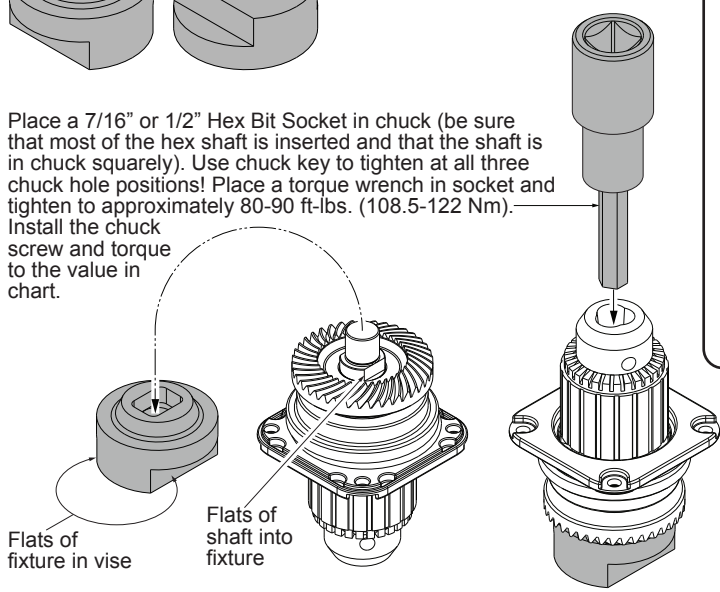

SCREW TORQUE SPECIFICATIONS

FIG.	PART NO.	WHERE USED	SEAT TORQUE	
			(KG/CM)	(IN/LBS)
1	06-75-3150	Chuck Screw	101-115	88-100
2	48-66-1381	1/2" Chuck (2807-20 only)	1100-1200	955-1042
3	06-82-5411	Output Assembly	44-50	38-43.5
12	05-88-9915	Top Handle	60-65	52-56
23	06-82-0165	High Voltage Terminal	5-9	4.5-7.5
27	06-82-5324	Pinion Bearing Plate	46-58	40-50
34	06-81-5376	Motor Cage Assembly	13-17	11-14.5
35	06-82-0044	Handle Cover	18-22	15.5-19
35	06-82-0044	Handle Cover/Motor Cage	18-22	15.5-19
45	06-82-0130	Chuck Key Holder (2807-20 only)	10-14	9-12
49	06-82-2005	Gearcase Assembly	35-40	30-35
67	42-66-0050	7/16" Hex Chuck (2808-20 only)	1100-1200	955-1042

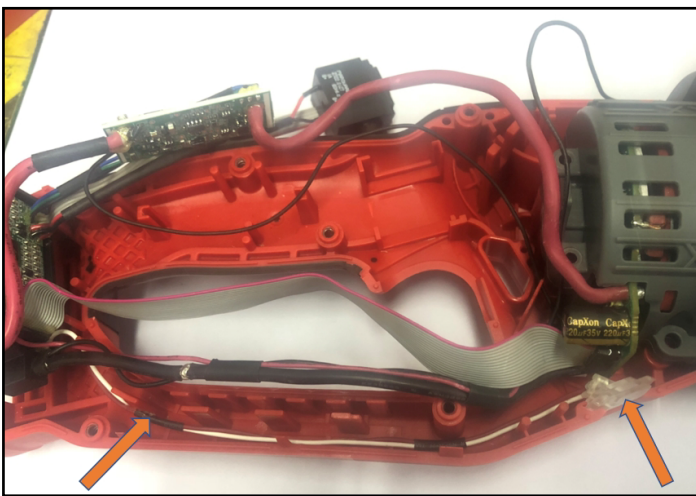

1. Place the LED into handle cavity. Route LED wires as shown.

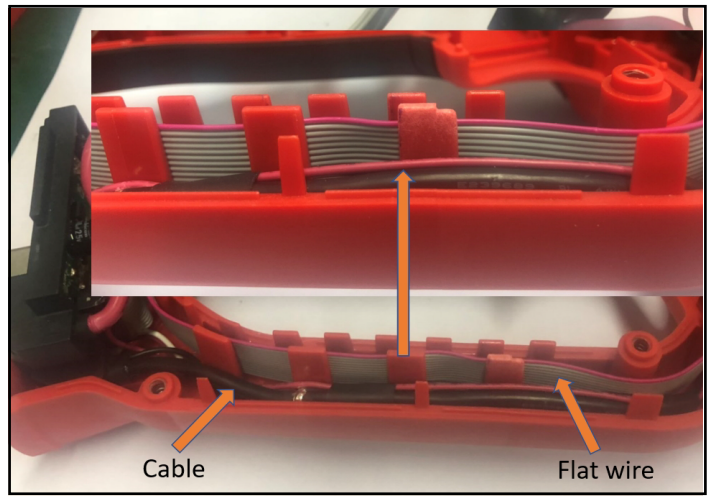

2. Place the cable (wire) and flat wire (ribbon cable) into channels and traps as shown. Be sure to press down into handle.

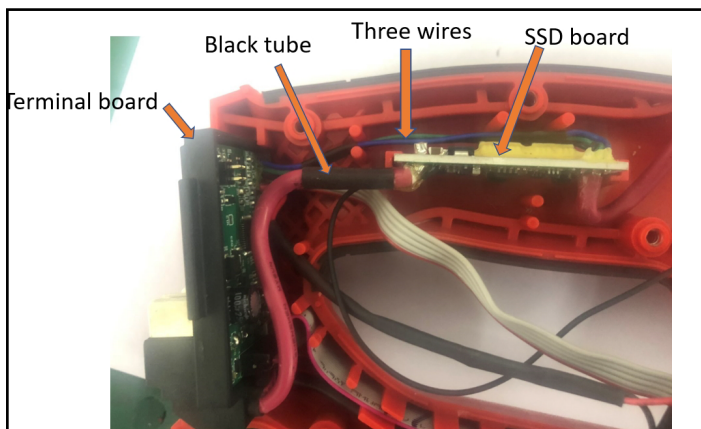

3. Place the terminal board and SSD board into the handle slots. Press big red wire with black tube below the ribs. Route the three thin wires as shown.

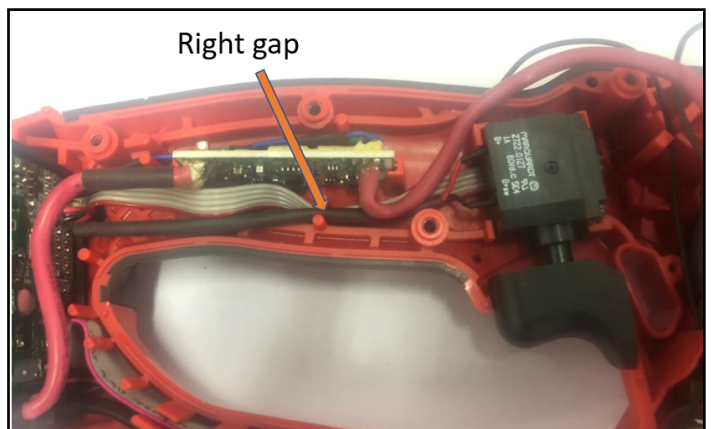

4. Install the on-off switch into handle cavity. Route the two thin wires (in black sleeve) and the four wire ribbon cable in traps and right gap as shown.

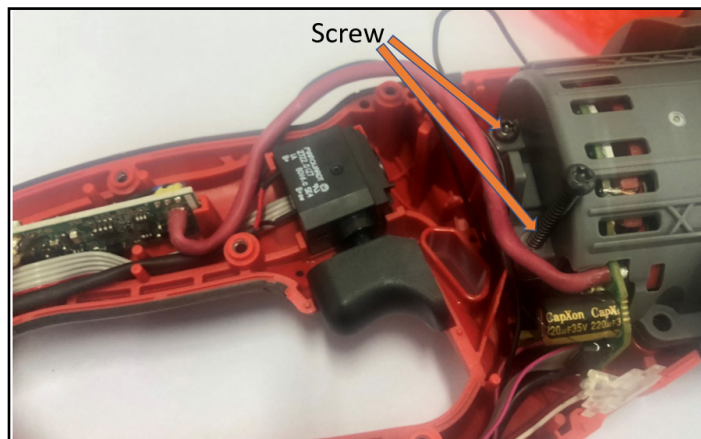

5. Secure the motor cage assembly to handle support with screws.

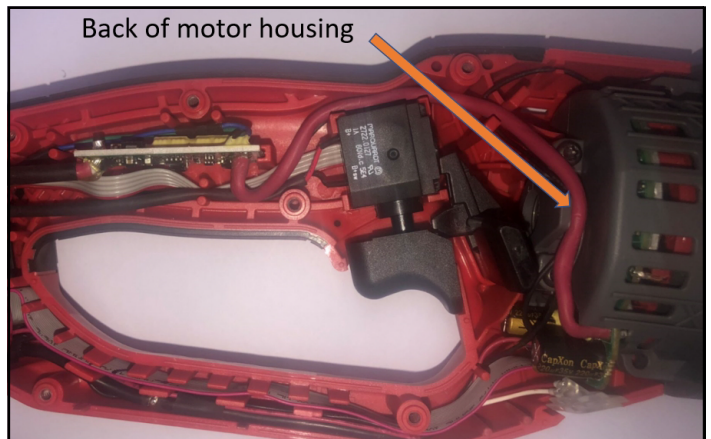

6. Route the two thin black wires through trap at the back of the motor cage. Place the large red wire over the thin wires in that trap. Continue routing large red wire as shown.

AS AN AID TO REASSEMBLY, TAKE NOTICE OF WIRE ROUTING AND POSITION IN WIRE GUIDES AND TRAPS WHILE DISMANTLING TOOL.

BE SURE THAT ALL COMPONENTS OF THE ELECTRONICS KIT ARE SEATED FIRMLY AND SQUARELY IN THE HANDLE RECESSES.

AVOID PINCHED WIRES, BE SURE THAT ALL WIRES AND SLEEVES ARE PRESSED COMPLETELY DOWN IN WIRE GUIDES AND TRAPS.

PRIOR TO INSTALLING THE HANDLE COVER ONTO THE HANDLE SUPPORT, BE SURE THAT THERE ARE NO INTERFERENCES.