



SERVICE PARTS LIST

BULLETIN NO.
54-22-1046

SPECIFY CATALOG NO. AND SERIAL NO. WHEN ORDERING PARTS		REVISED BULLETIN	DATE
2" DIE GRINDER		54-22-1045	Sept. 2022
CATALOG NO.	5196	WIRING INSTRUCTION 58-01-0314	
	STARTING SERIAL NO.	675E	

Collets

The collet must be attached to the collet nut before it is put into the collet shaft. Be sure that the size of the collet matches the size of the bit shank being used. If the wrong size bit shank is used, the collet may break. For attaching or detaching the collet nut to the collet, follow the illustrated instructions.

Attaching Collet to Collet Nut



To assemble, place the narrow end of the collet on an even surface. Take the nut and place it over the collet (Fig. 1).



Position nut squarely over collet with the smaller opening of the nut facing up (Fig. 2).

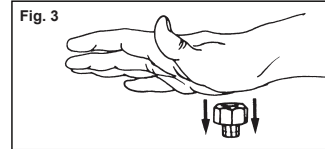

Snap nut and collet together by firmly applying downward pressure into assembly with palm of hand (Fig. 3).

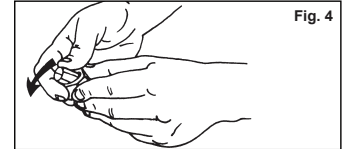

To remove collet from nut, hold nut firmly with one hand and press the collet to one side with the other hand (Fig. 4).

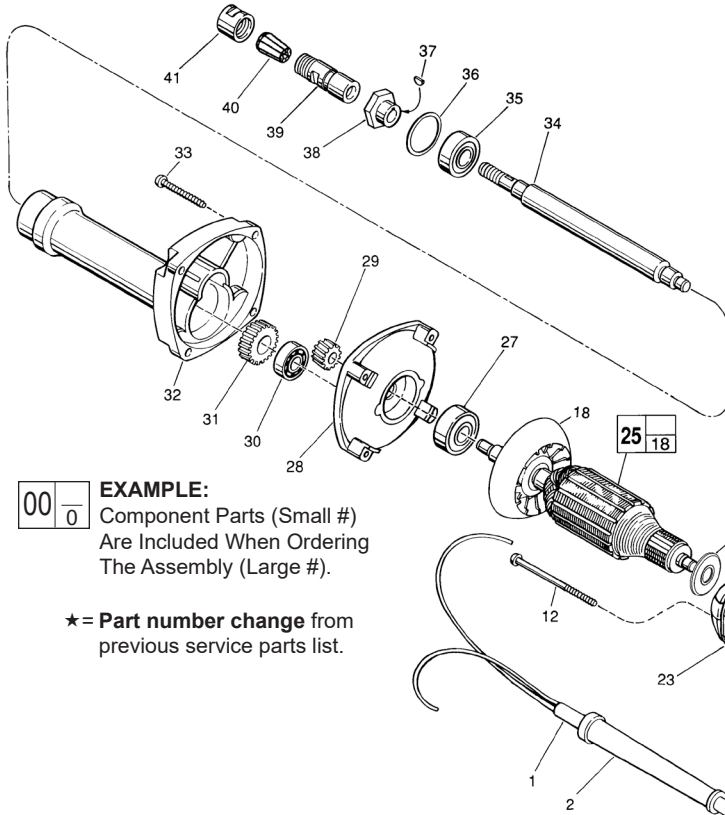

00/0

EXAMPLE:
Component Parts (Small #)
Are Included When Ordering
The Assembly (Large #).

★ = Part number change from
previous service parts list.

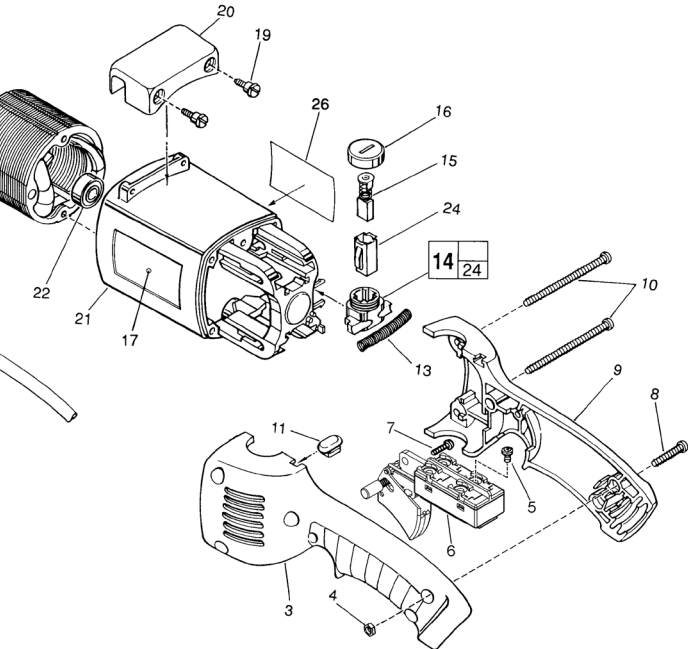

FIG.	PART NO.	DESCRIPTION OF PART	NO. REQ.
1	22-64-0785	Cord Set	(1)
2	44-76-0050	Cord Protector	(1)
★ 3	31-44-1717	Left Handle Half	(1)
4	06-55-1050	10-24 Hex Nut	(5)
★ 5	05-78-0305	Switch Screw T-15	(4)
★ 6	23-66-1801	Switch	(1)
7	06-82-7409	8-16 x 1/2" Pan Hd. Plastite T-20	(1)
8	06-82-2568	10-24 x 7/8" Pan Hd. Slit. T-25	(3)
★ 9	31-44-1718	Right Handle Half	(1)
10	06-82-2598	10-24 x 2-3/4" Pan Hd. Slit. T-25	(2)
11	42-38-0190	Bumper	(1)
12	06-82-7375	8-16 x 2-1/2" Taptite T-20	(2)
13	40-50-7770	Brush Holder Spring	(2)
14	22-22-1325	Brush Holder Assembly	(2)
15	22-18-0680	Carbon Brush Assembly	(2)
16	23-44-0210	Brush Retaining Screw	(2)
17	12-20-5200	Service Nameplate Kit	(1)
18	-----	Fan	(1)
19	45-04-0720	Shoulder Screw	(2)
20	31-70-0125	Tool Rest	(1)
21	31-50-0548	Motor Housing	(1)
22	02-04-0845	Ball Bearing	(1)
23	18-50-0090	Field	(1)
24	22-20-0660	Brush Tube	(2)
25	16-50-1130	Armature	(1)
★ 26	10-98-1806	Warning Label	(1)
27	02-04-1860	Ball Bearing	(1)
28	28-28-1565	Diaphragm	(1)
29	32-02-3020	Armature Gear	(1)
30	02-04-0910	Ball Bearing	(1)
31	32-75-3030	Spindle Gear	(1)
32	28-50-6190	Spindle Housing	(1)
33	06-82-7407	10-14 x 1-9/16" Pan Hd. T-20	(4)

FIG.	PART NO.	DESCRIPTION OF PART	NO. REQ.
34	38-50-5320	Spindle Shaft	(1)
35	02-04-1860	Ball Bearing	(1)
36	34-80-2600	Internal Retaining Ring	(1)
37	06-42-0400	Woodruff Key	(1)
38	43-34-0390	Collet Flange	(1)
39	48-68-0040	1/4" Collet Body	(1)
40	48-66-0975	1/4" Collet	(1)
41	48-68-0031	1/4" Collet Nut	(1)
42	23-16-1700	Commutator Insulator	(1)
	49-96-4040	1/2" Open End Wrench	(1)
	49-96-4090	11/16" Open End Wrench	(1)
	49-96-4075	1" Open End Wrench	(1)

FIG. LUBRICATION

32 **Important!** Completely clean out old grease from the spindle housing and replace with 3/4 Oz. Type "Y" Grease, No. 49-08-5270.