



SERVICE PARTS LIST

BULLETIN NO.
54-47-0202

SPECIFY CATALOG NO. AND SERIAL NO. WHEN ORDERING PARTS		REVISED BULLETIN 54-47-0201	DATE June 2022
M12™ PEX Expander			
CATALOG NO.	2432-20	STARTING SERIAL NO.	C62C
		WIRING INSTRUCTION SEE PAGE 3	

EXAMPLE:
Component Parts (Small #) Are Included
When Ordering The Assembly (Large #).

The Gearcase Assembly (17) comes with a Motor Mount Bracket (31) that must be removed and discarded when servicing. A Motor Mount Bracket already exists on the Motor Assembly (34).

★ = Part number change from previous service parts list.

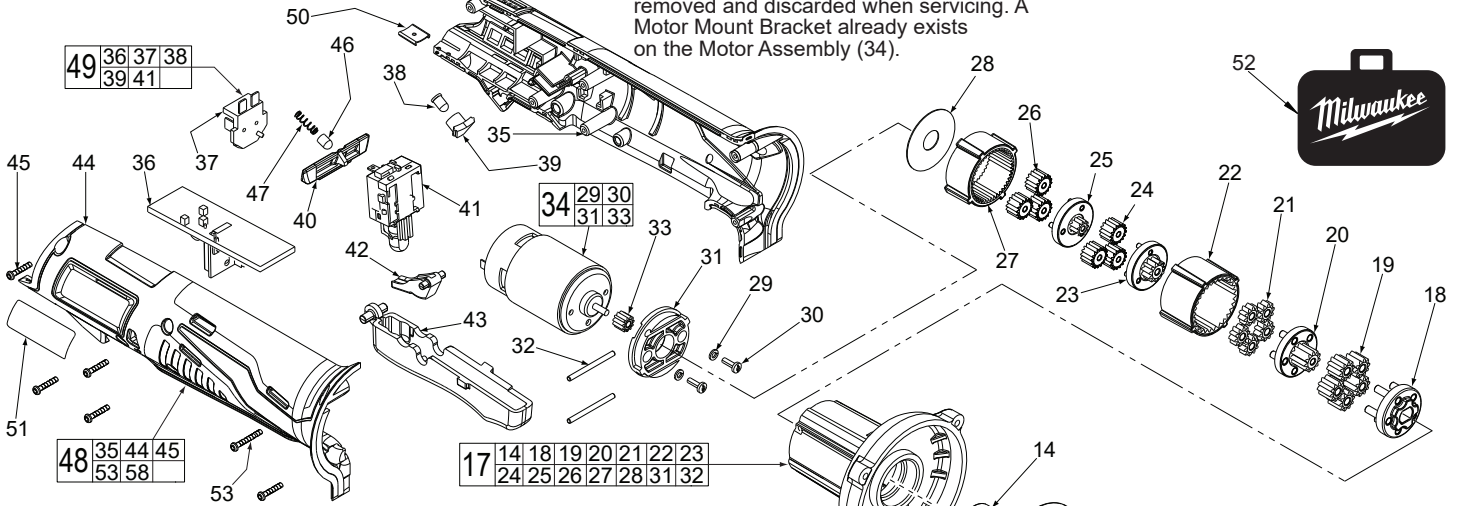

FIG.	PART NO.	DESCRIPTION OF PART	NO. REQ.
1	See Chart	Head Assembly (Optional, see chart)	(1)
1.1	-----	Segment	(6)
1.2	-----	Garter	(1)
1.3	-----	Ring	(1)
★ 2	45-22-1026	Steel Sleeve	(1)
3	34-40-1050	O-Ring	(1)
4	42-76-0950	Rotating Collar	(1)
5	40-50-1575	Collar Spring	(1)
★ 6	44-60-0413	Pin	(1)
★ 7	42-76-0064	Drive Collar	(1)
★ 8	40-50-2532	Return Spring	(1)
★ 9	32-75-1595	Spindle	(1)
★ 10	44-96-0260	Roller	(1)
★ 11	44-66-2180	Roller Pin	(1)
12	28-20-1390	Gearcase Cover Assembly	(1)
13	06-82-5320	8-32 x 5/8" Pan Hd. Slit. Tapt. T-20 Scr.	(4)
14	02-04-1005	Ball Bearing	(1)
15	36-10-0680	Cam and Shaft Assembly	(1)
17	28-14-2332	Gearcase Assembly	(1)
18	-----	4th Carrier	(1)
19	-----	4th Planet Gear	(5)
20	-----	4th Sun Gear	(1)
21	-----	3rd Planet Gear	(1)
22	-----	3rd and 4th Ring Gear	(5)
23	-----	3rd Sun Gear	(1)
24	-----	2nd Planet Gear	(3)
25	-----	2nd Sun Gear	(1)
26	-----	1st Planet Gear	(3)
27	-----	1st and 2nd Ring Gear	(1)
28	-----	Washer	(1)
29	45-88-1980	Spring Washer	(2)
30	05-81-0205	M3 x 6 Pan Hd. Motor Screw	(2)
31	42-36-0840	Motor Mount Bracket	(1)
32	44-60-1530	Motor Mount Pin	(2)
33	-----	Motor Pinion	(1)
34	23-30-0625	Motor Assembly	(1)
35	-----	Handle Halve - Left	(1)
36	-----	PCBA	(1)
37	-----	Connector Block	(1)
38	-----	LED	(1)
39	-----	LED Holder	(1)
40	31-76-0325	Shuttle	(1)
41	-----	Switch	(1)
42	44-10-0825	Trigger Lever	(1)
43	31-92-0570	Trigger	(1)
44	-----	Handle Halve - Right	(1)
45	06-82-1080	M3 x 14 Pan Hd. Plast. T-10 Screw	(5)
46	43-72-0430	Shuttle Detent	(1)
47	40-50-1475	Shuttle Detent Spring	(1)
48	31-44-2475	Handle Kit	(1)
49	23-66-2840	Switch Assembly	(1)
50	42-70-0058	Housing Connection Clip	(1)
51	12-20-2432	Service Nameplate	(1)
52	42-55-2400	Carrying Case, Optional	(1)
53	05-88-0675	M3 x 20 Pan Hd. Plast. T-10 Screw	(1)
55	43-74-0730	Belt Hook	(1)
56	02-04-1022	Ball Bearing	(1)
57	10-20-2002	Warning Label (Not Shown)	(1)
58	-----	Fuel Gauge Label (Not Shown)	(1)
59	45-88-1485	Flat Washer	(1)

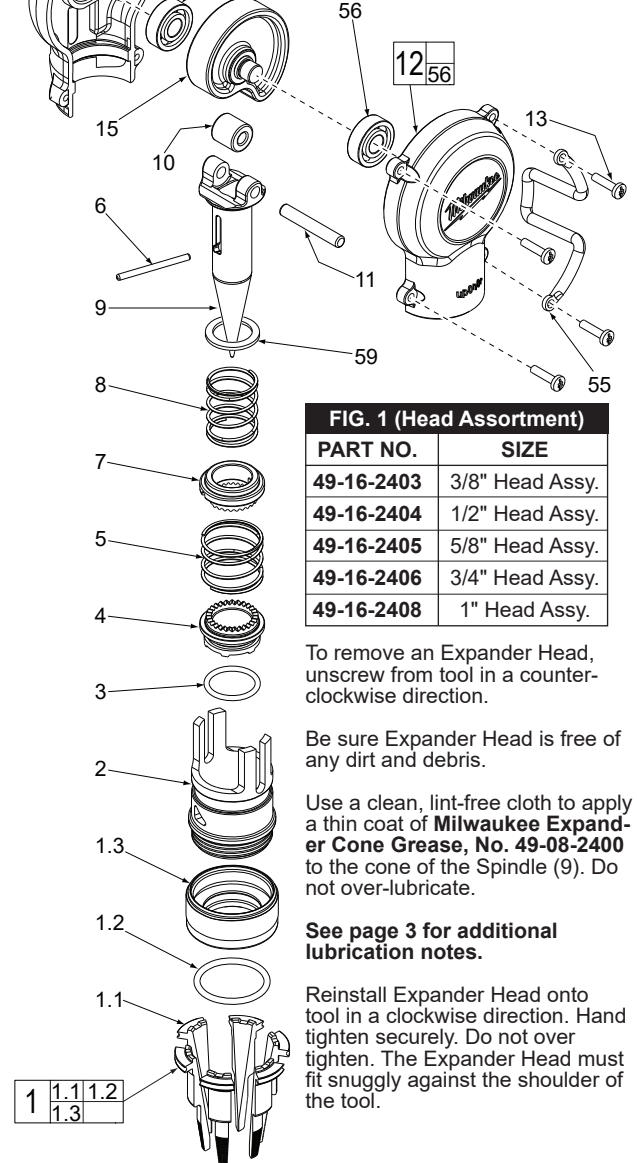

FIG. 1 (Head Assortment)

PART NO.	SIZE
49-16-2403	3/8" Head Assy.
49-16-2404	1/2" Head Assy.
49-16-2405	5/8" Head Assy.
49-16-2406	3/4" Head Assy.
49-16-2408	1" Head Assy.

To remove an Expander Head, unscrew from tool in a counter-clockwise direction.

Be sure Expander Head is free of any dirt and debris.

Use a clean, lint-free cloth to apply a thin coat of **Milwaukee Expander Cone Grease, No. 49-08-2400** to the cone of the Spindle (9). Do not over-lubricate.

See page 3 for additional lubrication notes.

Reinstall Expander Head onto tool in a clockwise direction. Hand tighten securely. Do not over tighten. The Expander Head must fit snugly against the shoulder of the tool.

LUBRICATION NOTES:

Use Type 'L' Grease, No. 49-08-4175

Total amount approx. 12 grams (.4 ounces)

When servicing, remove 90-95% of the existing grease prior to installing Type 'L'. Original grease maybe similar in color but not compatible with 'L'.

Place 6 grams (.2 ounces) of grease in this area of Gearcase Assembly behind the Cam and Shaft Assembly.

Apply grease to both ends of Cam Shaft and lightly coat the entire exterior of Cam. Approx. 2 grams of grease

Lightly coat Roller with grease.

Lightly coat Pin with grease.

Lightly coat Roller Pin with grease.

Apply a light coating of grease to the cylindrical portion (not the cone) of the Spindle. Lightly coat all surfaces of the Collar Spring and the Return Spring. Approx. 1 gram.

Place grease on the entire surface of the Rotating Collar and Drive Collar, being sure to apply heavier amounts on the teeth. Lightly coat the O-Ring before installing on the Rotating Collar. Approx. 1.8 grams.

Coat with grease both sides of the legs of the Frame. Coat the interior of the Frame prior to installing the Rotating Collar, Drive Collar, Springs and O-Ring.

Lightly grease the exterior surface of the Frame with the two triangle features.

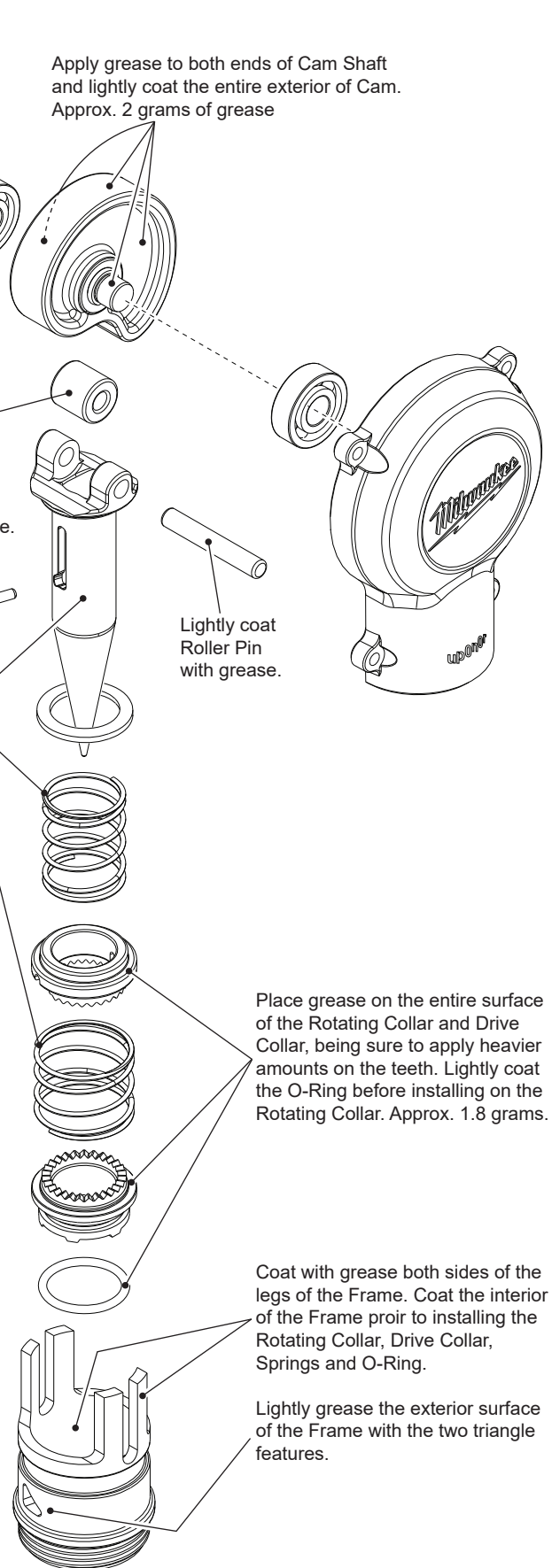
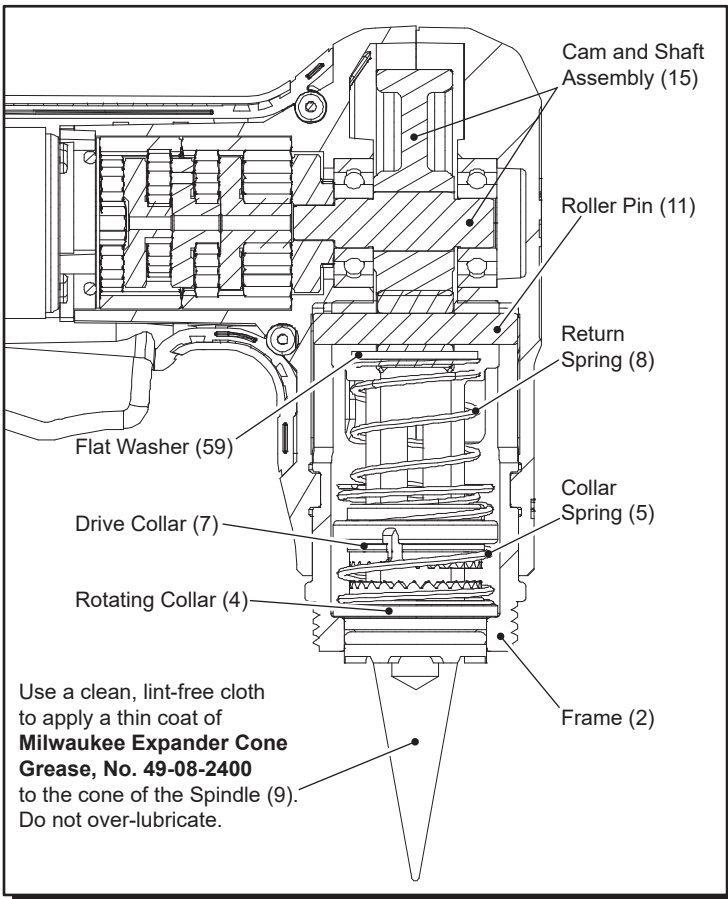

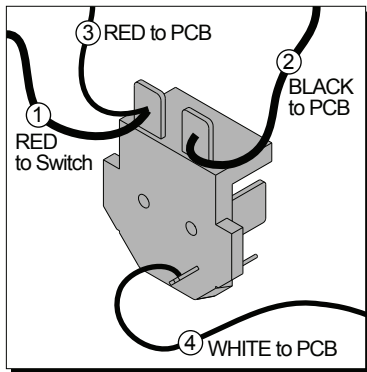

CONNECTOR BLOCK

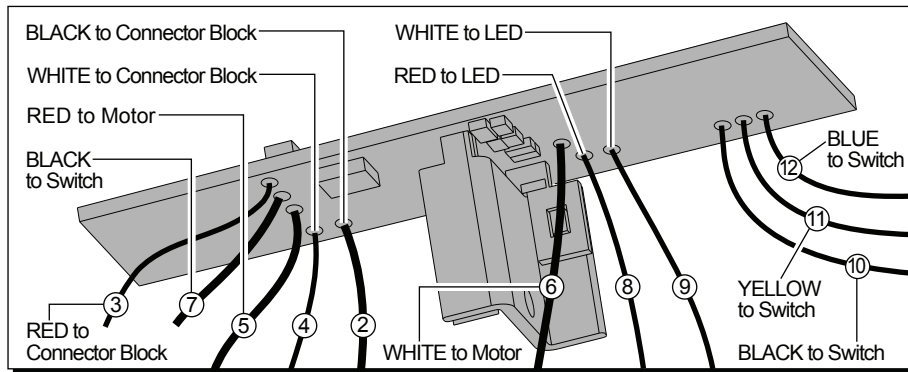

PCB ASSEMBLY

NOTE:
Black wire #2 (on the opposite side of Terminal Block) and red wire #5 (on the opposite side of Motor Assembly) are not shown in this side view for clarity.

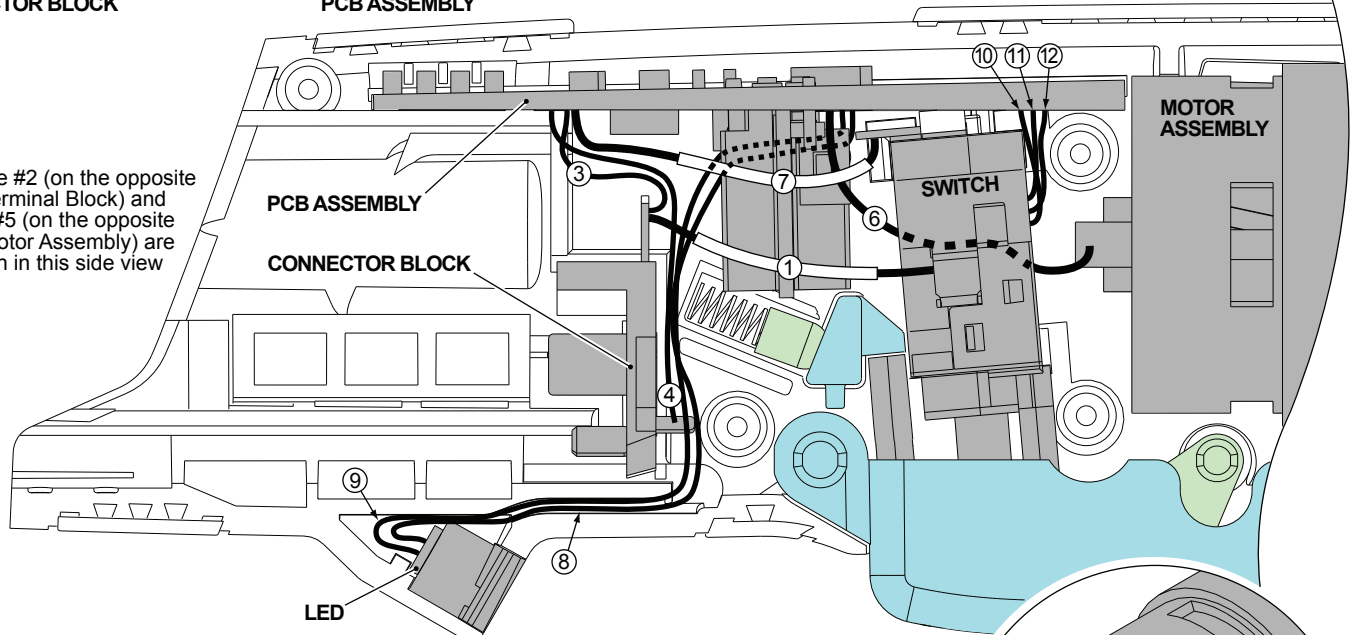

AS AN AID TO REASSEMBLY, TAKE NOTICE OF WIRE ROUTING AND POSITION IN WIRE GUIDES AND TRAPS WHILE DISMANTLING TOOL.

BE CAREFUL AND AVOID PINCHING WIRES BETWEEN HANDLE HALVES WHEN ASSEMBLING.

NOTE:
Switch Assembly (23-66-2840) consists of: switch, PCB assembly, connector block and LED assembly.

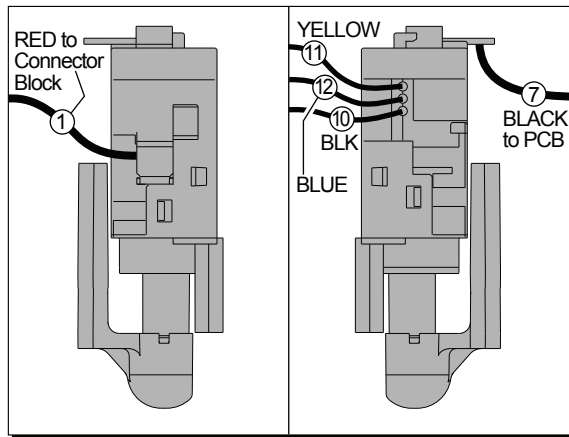

SWITCH

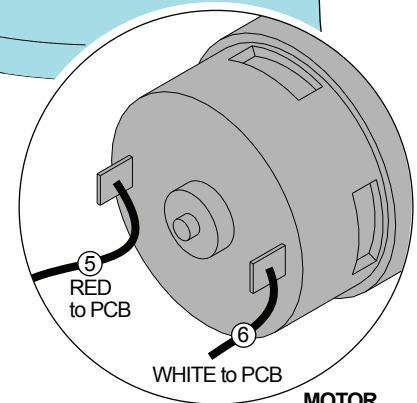

MOTOR ASSEMBLY

WIRING SPECIFICATIONS

Wire No.	Wire Color	Origin or Gauge	Length	Terminals, Connectors and 1 or 2 End Wire Preparation
1	Red	23-66-2840	-----	Component of switch assembly. Soldered to switch and connector block as shown.
2	Black	23-66-2840	-----	Component of switch assembly. Soldered to connector block and PCB assembly as shown.
3	Black	23-66-2840	-----	Component of switch assembly. Soldered to connector block and PCB assembly as shown.
4	White	23-66-2840	-----	Component of switch assembly. Soldered to connector block and PCB assembly as shown.
5	Red	23-66-2840	-----	Component of switch assembly. Soldered to motor assembly and PCB assembly as shown.
6	White	23-66-2840	-----	Component of switch assembly. Soldered to motor assembly and PCB assembly as shown.
7	Black	23-66-2840	-----	Component of switch assembly. Soldered to switch and PCB assembly as shown.
8	Red	23-66-2840	-----	Component of switch assembly. Routed from LED and soldered to PCB assembly as shown.
9	White	23-66-2840	-----	Component of switch assembly. Routed from LED and soldered to PCB assembly as shown.
10	Black	23-66-2840	-----	Component of switch assembly. Route from switch and soldered to PCB assembly as shown.
11	Yellow	23-66-2840	-----	Component of switch assembly. Route from switch and soldered to PCB assembly as shown.
12	Blue	23-66-2840	-----	Component of switch assembly. Route from switch and soldered to PCB assembly as shown.