



SERVICE PARTS LIST

BULLETIN NO.
54-49-0020

SPECIFY CATALOG NO. AND SERIAL NO. WHEN ORDERING PARTS		REVISED BULLETIN	DATE
PIPE LOCK			Sept. 2018
CATALOG NO. 48-22-5001	SERIAL NUMBER	WIRING INSTRUCTION	

EXAMPLE:
Component Parts (Small #) Are Included
When Ordering The Assembly (Large #).

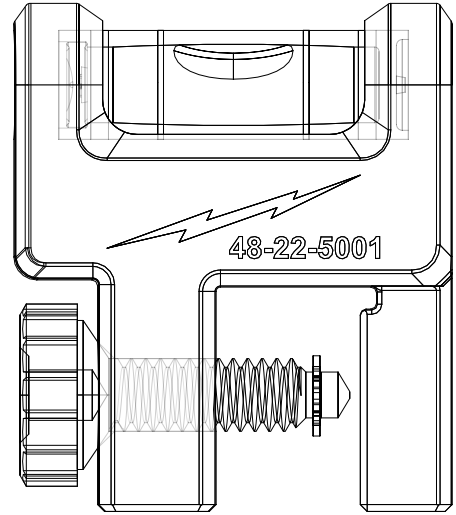
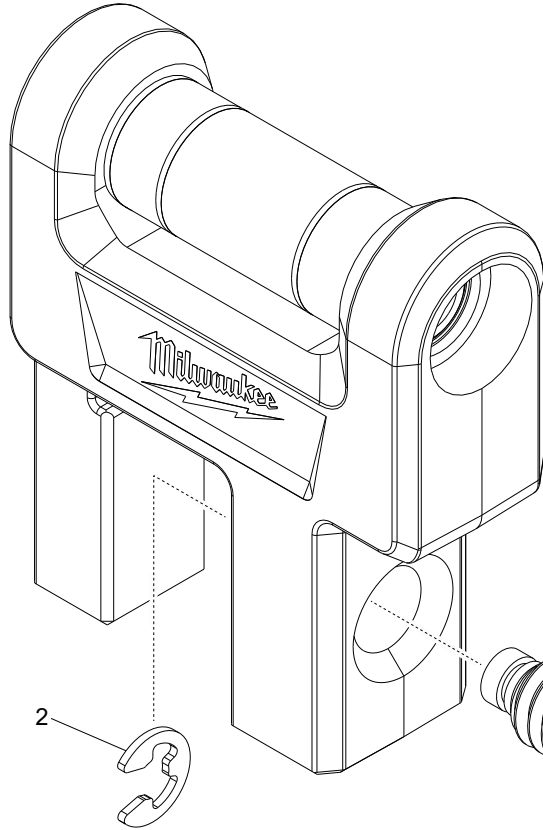

FIG.	PART NO.	DESCRIPTION OF PART	NO. REQ.
1	14-46-5120	Pipe Lock Thumbscrew Assembly	(1)
2	34-60-0137	E Clip	(1)