

WIRING INSTRUCTIONS

TITLE

TRIPLE REDUCTION "D" HANDLE TOOLS

**BULLETIN
58-01-0181**

MILWAUKEE ELECTRIC TOOL CORP.

13135 WEST LISBON RD. BROOKFIELD, WIS

DATE
Sept. '78

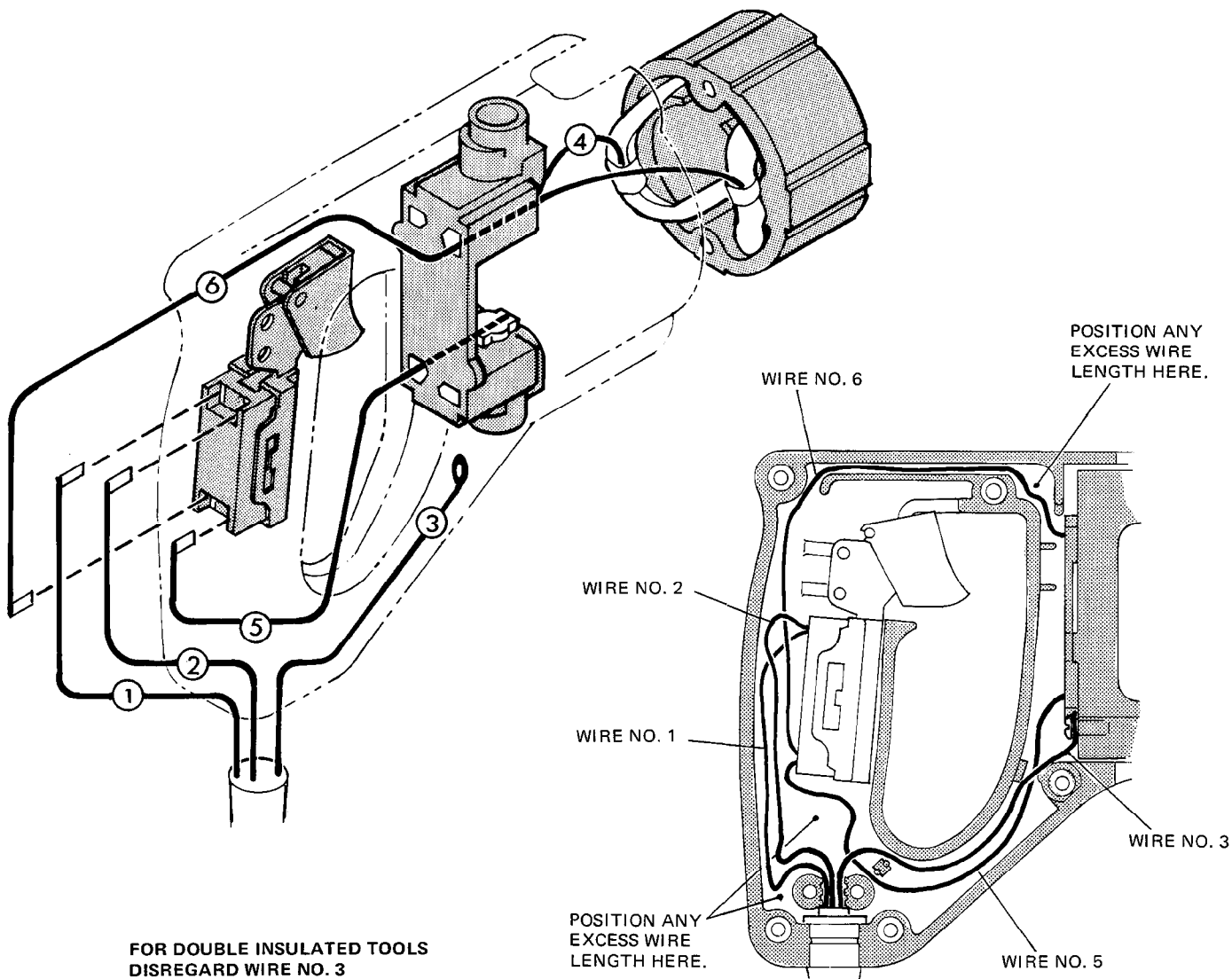

**FOR DOUBLE INSULATED TOOLS
DISREGARD WIRE NO. 3**

WIRING SPECIFICATIONS

Wire No.	Wire Color	Origin or Gauge	Length	Terminals, Connectors and 1 or 2 End Wire Preparation.
1	Black	Cord	4-3/4"	Strip 1/4" for T1
2	White	Cord	4-3/4"	Strip 1/4" for T1
3	Green	Cord	4-3/4"	Strip 3/16" for T2
4	Red	Field	2-1/4"	Strip 1/4" for T1
5	White	18	8-3/4"	Strip 1/4" for T1/Strip 1/4" for T1
6	Brown	Field	10"	Strip 1/4" for T1

NOTE:
All leads must be held to $\pm 1/8"$.
All field leads to be measured from and perpendicular to laminations.
All lead lengths are before stripping.

TERMINAL DESCRIPTION		
Code	Part No.	Qty.
T1	22-44-0090	6
T2	23-74-0390	1
CONNECTOR DESCRIPTION		
Code	Part No.	Qty.