

# WIRING INSTRUCTIONS

TITLE

**D-HANDLE TOOLS**

**BULLETIN  
58-01-0224**

MILWAUKEE ELECTRIC TOOL CORP. 13135 WEST LISBON RD. BROOKFIELD, WIS.

DATE  
Jan. 2009

**SEE REVERSE SIDE  
FOR TOOLS WITH  
ALTERNATIVE SWITCH  
CONFIGURATION**

END OF LEAD WIRE  
INSULATION MUST  
BE BELOW THE  
OPENING IN THE  
SWITCH (4X)

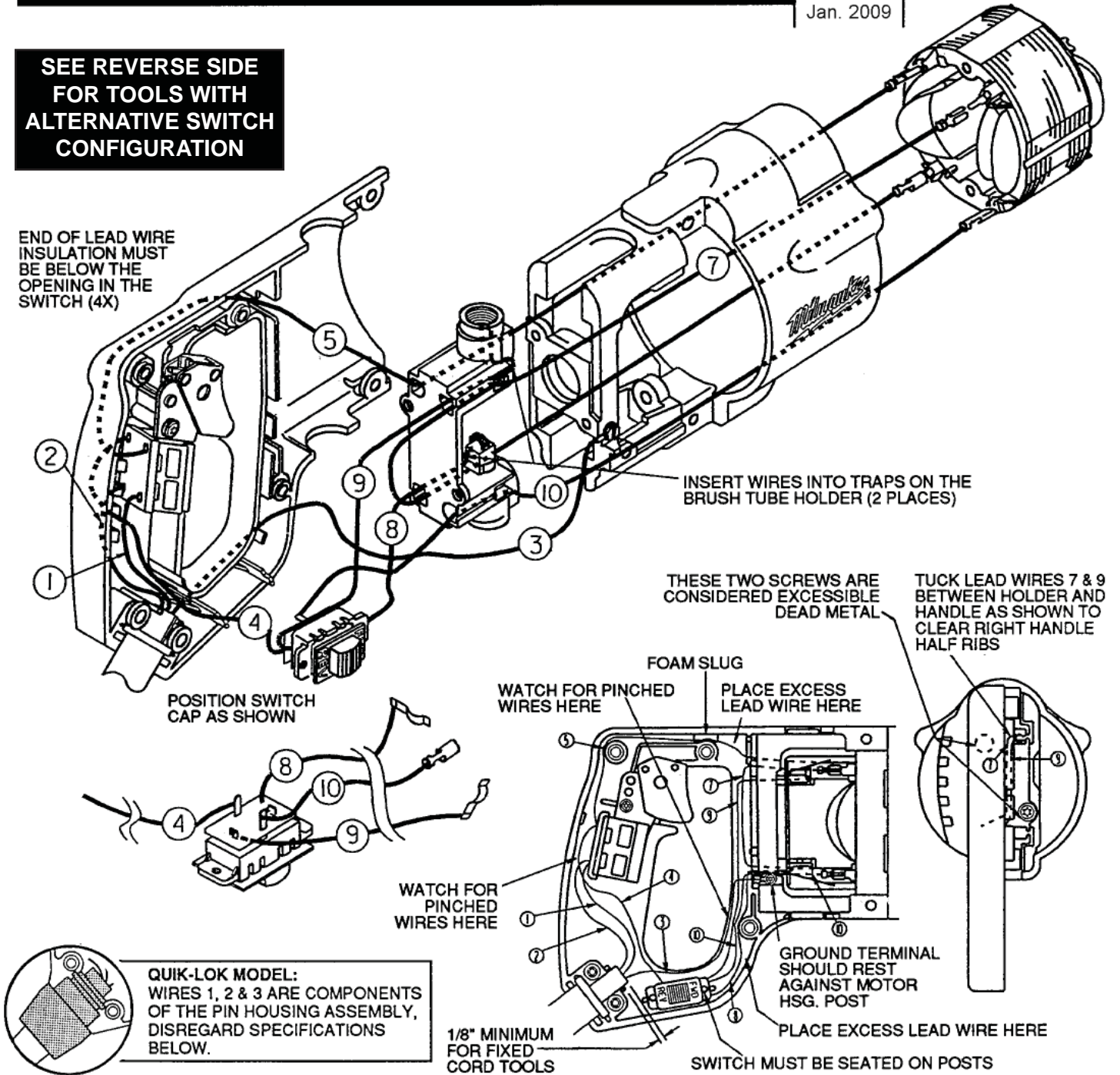

**QUIK-LOK MODEL:**  
WIRES 1, 2 & 3 ARE COMPONENTS  
OF THE PIN HOUSING ASSEMBLY,  
DISREGARD SPECIFICATIONS  
BELOW.

## WIRING SPECIFICATIONS

Wire No.	Wire Color	Origin or Part No.	Gauge	Length	Terminals, Connectors and End Wire Preparation
1	White	Cord	18	3-3/4"	Strip 3/8" and tin.
2	Black	Cord	18	3-3/4"	Strip 3/8" and tin.
3	Green	Cord	18	5-1/2"	Strip 3/16" for T1.
4	Black	Rev. Switch	18	5-1/4"	Strip 3/8" and tin.
5	White	23-94-6115	18	8"	Strip 3/16" for T3 / Strip 3/8" and tin.
7	Yellow	23-94-6110	18	5-5/16"	Strip both ends 3/16" for T3.
8	Black	Rev. Switch	18	5-1/4"	Strip 1/4" for T2.
9	Black	Rev. Switch	18	7-1/4"	Strip 1/4" for T2.
10	Brown	Rev. Switch	18	5-1/4"	Strip 3/16" for T3.

BULK LEAD WIRE - BULLETIN 58-01-0003

**NOTE:**

All leads must be held to  $\pm 1/8"$ .  
All lead lengths are before stripping.

### TERMINAL DESCRIPTION

Code	Part No.	Qty.
T1	23-74-0896	1
T2	23-74-0410	2
T3	23-74-1060	4

# WIRING INSTRUCTIONS

TITLE

D-HANDLE TOOLS

BULLETIN

MILWAUKEE ELECTRIC TOOL CORP. 13135 WEST LISBON RD. BROOKFIELD, WIS.

DATE

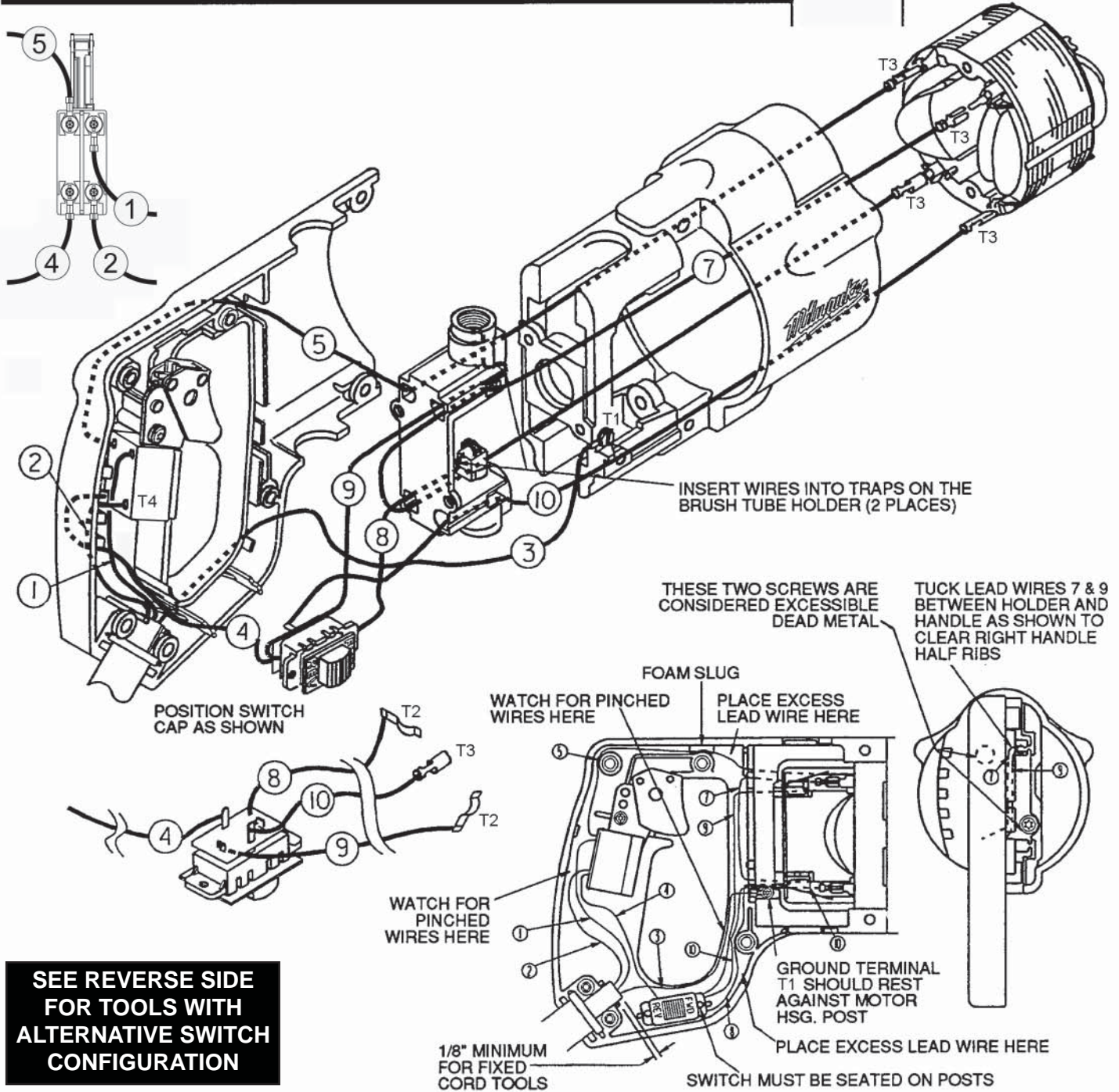

**SEE REVERSE SIDE FOR TOOLS WITH ALTERNATIVE SWITCH CONFIGURATION**

## WIRING SPECIFICATIONS

Wire No.	Wire Color	Origin or Part No.	Gauge	Length	Terminals, Connectors and End Wire Preparation
1	White	Cord	18	3-3/4"	Strip 3/16" for T4.
2	Black	Cord	18	3-3/4"	Strip 3/16" for T4.
3	Green	Cord	18	5-1/2"	Strip 3/16" for T1.
4	Black	Rev. Switch	18	5-1/4"	Strip 3/16" for T4.
5	White	23-94-4296	18	9-1/4"	Strip 3/16" for T3 / Strip 3/16" for T4.
7	Yellow	23-94-6110	18	5-5/16"	Strip both ends 3/16" for T3.
8	Black	Rev. Switch	18	5-1/4"	Strip 1/4" for T2.
9	Black	Rev. Switch	18	7-1/4"	Strip 1/4" for T2.
10	Brown	Rev. Switch	18	5-1/4"	Strip 3/16" for T3.

BULK LEAD WIRE - BULLETIN 58-01-0003

**NOTE:**

All leads must be held to ± 1/8".  
All lead lengths are before stripping.

## TERMINAL DESCRIPTION

Code	Part No.	Qty.
T1	23-74-0896	1
T2	23-74-0410	2
T3	23-74-1060	4
T4	23-74-0850	4