

WIRING INSTRUCTIONS

TITLE	D-HANDLE TOOLS	BULLETIN
MILWAUKEE ELECTRIC TOOL CORP.	13135 WEST LISBON RD. BROOKFIELD, WIS.	58-01-0226
	DATE	
	Jan. 2009	

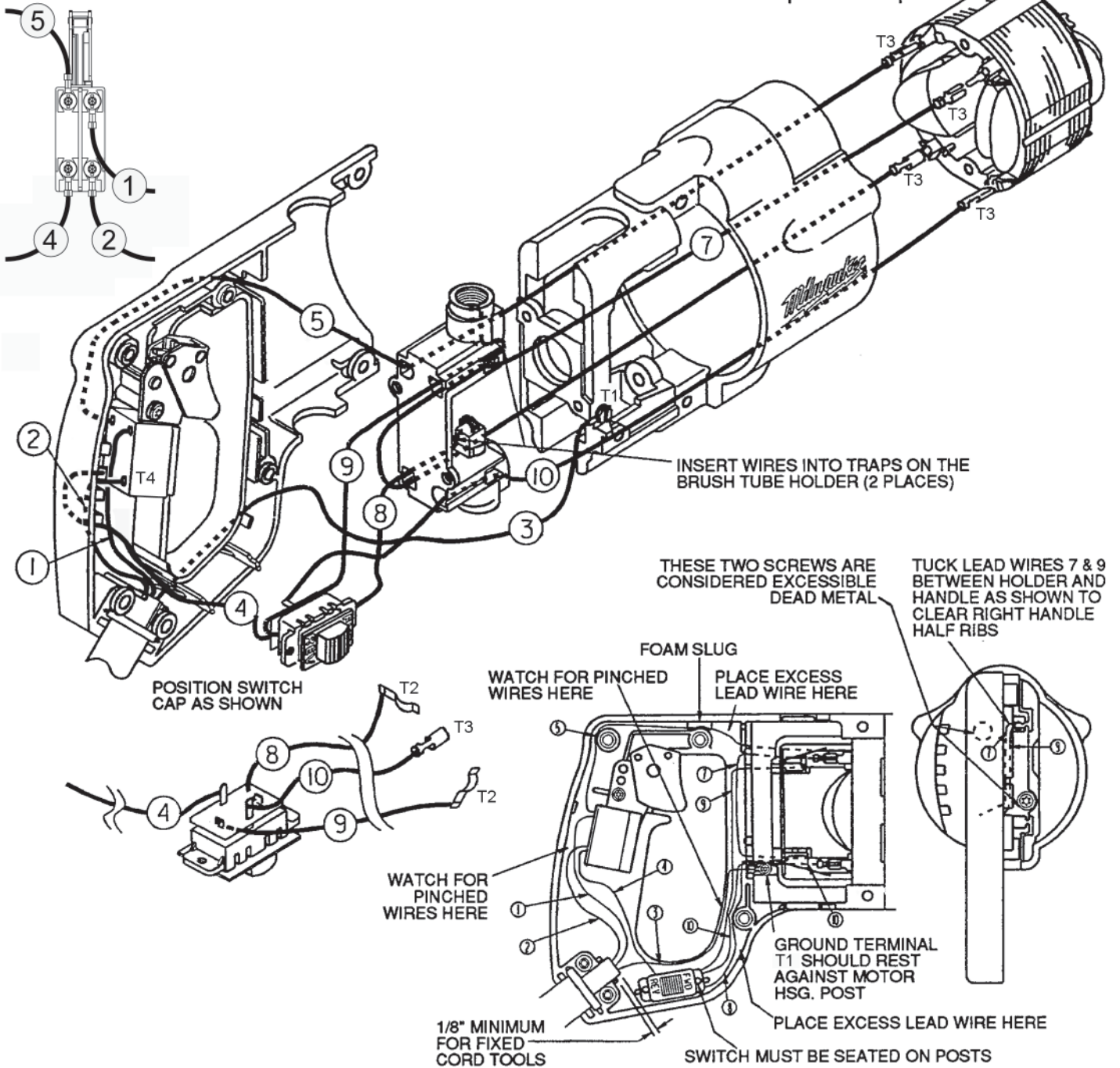

WIRING SPECIFICATIONS					
Wire No.	Wire Color	Origin or Part No.	Gauge	Length	Terminals, Connectors and End Wire Preparation
1	White	Cord	18	3-3/4"	Strip 3/16" for T4.
2	Black	Cord	18	3-3/4"	Strip 3/16" for T4.
3	Green	Cord	18	5-1/2"	Strip 3/16" for T1.
4	Black	Rev. Switch	18	5-1/4"	Strip 3/16" for T4.
5	White	23-94-4296	18	9-1/4"	Strip 3/16" for T3 / Strip 3/16" for T4.
7	Yellow	23-94-6110	18	5-5/16"	Strip both ends 3/16" for T3.
8	Black	Rev. Switch	18	5-1/4"	Strip 1/4" for T2.
9	Black	Rev. Switch	18	7-1/4"	Strip 1/4" for T2.
10	Brown	Rev. Switch	18	5-1/4"	Strip 3/16" for T3.

BULK LEAD WIRE - BULLETIN 58-01-0003

NOTE:
All leads must be held to ± 1/8".
All lead lengths are before stripping.

TERMINAL DESCRIPTION		
Code	Part No.	Qty.
T1	23-74-0896	1
T2	23-74-0410	2
T3	23-74-1060	4
T4	23-74-0850	4