

# WIRING INSTRUCTIONS

**TITLE** TRIPLE REDUCTION REVERSING "D" HANDLE TOOLS

MILWAUKEE ELECTRIC TOOL CORP. 13135 WEST LISBON RD. BROOKFIELD, WIS

DATE  
Sept. '78

**BULLETIN**  
**58-01-0243**

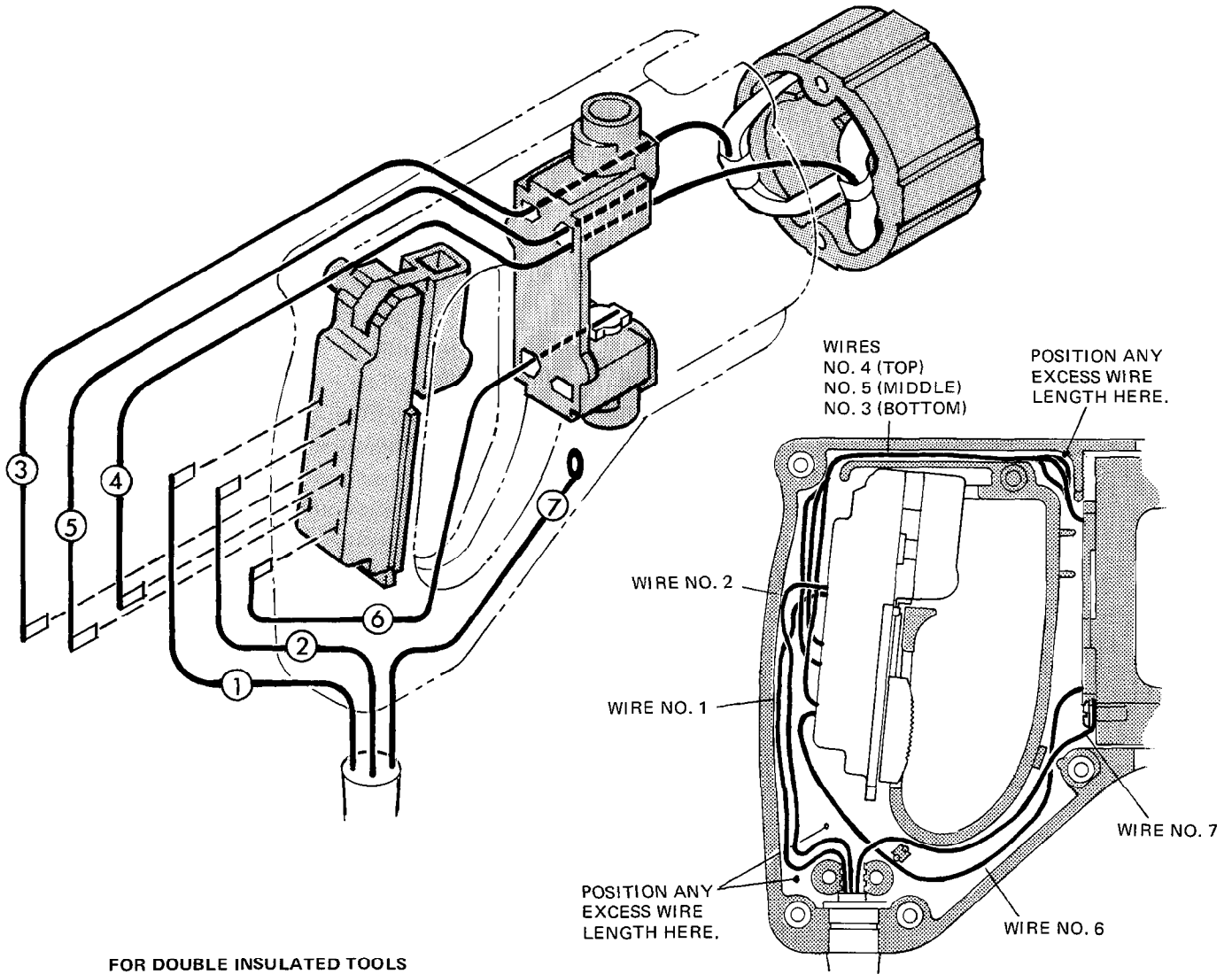

## WIRING SPECIFICATIONS

Wire No.	Wire Color	Origin or Gauge	Length	Terminals, Connectors and 1 or 2 End Wire Preparation.
1	Black	Cord	4-3/4"	Strip 1/4" for T1
2	White	Cord	4-3/4"	Strip 1/4" for T1
3	Red	Field	9"	Strip 1/4" for T1
4	Brown	Field	9"	Strip 1/4" for T1
5	Yellow	18	9"	Strip 1/4" for T1/Strip 1/4" for T1
6	White	18	8-3/4"	Strip 1/4" for T1/Strip 1/4" for T1
7	Green	Cord	4-3/4"	Strip wire 3/16" for T2

**NOTE:**

All leads must be held to  $\pm 1/8"$ .  
All field leads to be measured from and perpendicular to laminations.  
All lead lengths are before stripping.

### TERMINAL DESCRIPTION

Code	Part No.	Qty.
T1	22-44-0090	8
T2	23-74-0390	1

### CONNECTOR DESCRIPTION

Code	Part No.	Qty.