

WIRING INSTRUCTIONS

TITLE

CIRCULAR SAW

BULLETIN

58-01-0753

MILWAUKEE ELECTRIC TOOL CORP. 13135 WEST LISBON RD. BROOKFIELD, WIS.

DATE
July 2013

SEE REVERSE SIDE
FOR TOOLS WITH
ALTERNATIVE SWITCH
CONFIGURATION

NOTE: Wires to be inserted in switch so that insulation is subflush to opening.

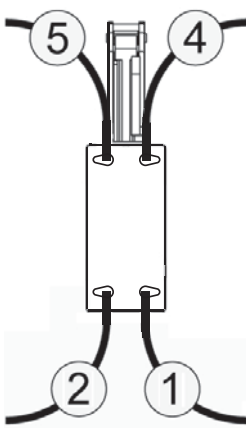

**Back View of Switch
23-66-0167**
Push in connections for tinned leads

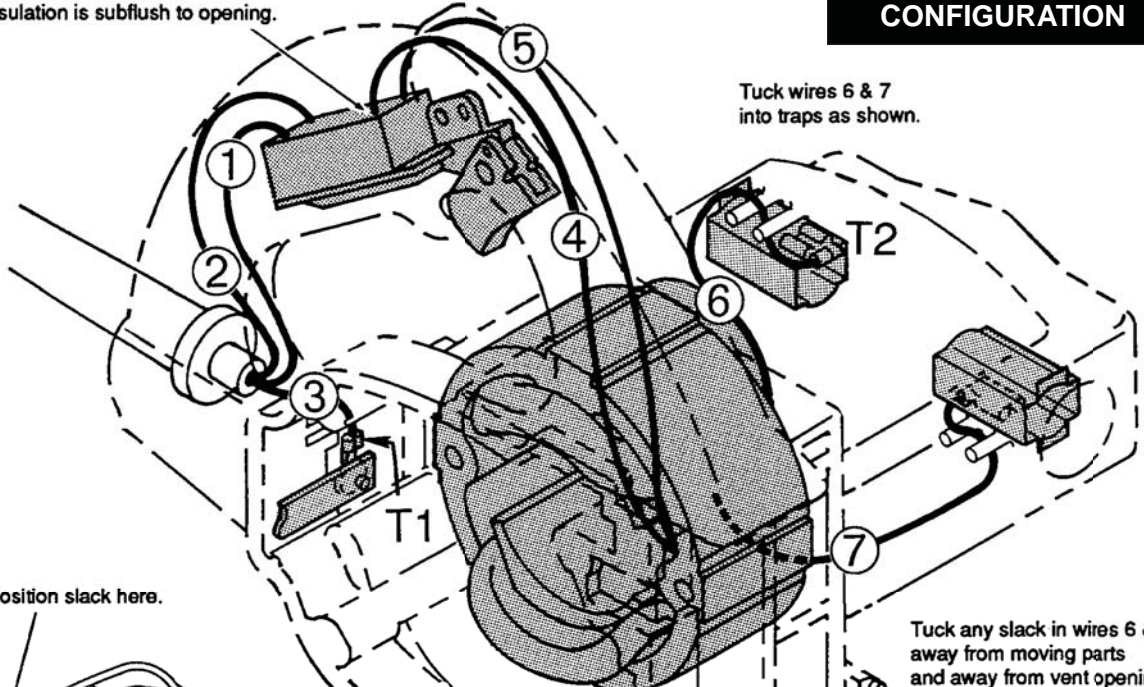

Tuck wires 6 & 7 into traps as shown.

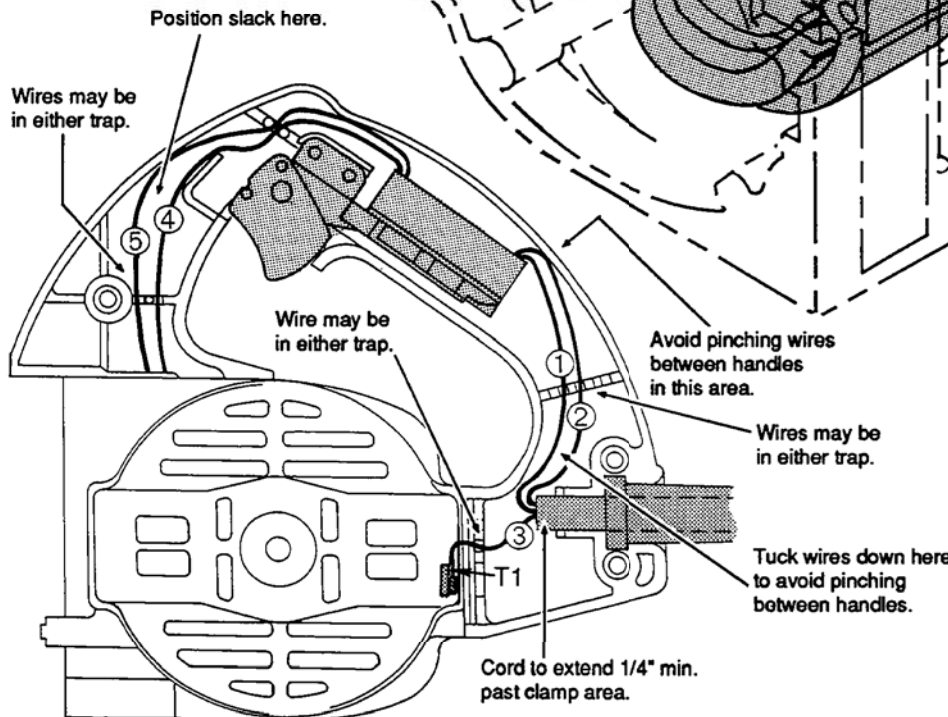

Tuck any slack in wires 6 & 7 away from moving parts and away from vent openings.

Push all trapped wires into bottom of wire traps.

**For Double Insulated Tools,
Disregard wire #3 and T1.**

WIRING SPECIFICATIONS

Wire No.	Wire Color	Origin or Part No.	Gauge	Length	Terminals, Connectors and End Wire Preparation
1	White	Cord	16	5"	Strip 3/8" and tin
2	Black	Cord	16	5"	Strip 3/8" and tin
3	Green	Cord	16	2-1/4"	Strip 3/16" for T1
4	Yellow	Field	16	8-7/8"	Strip 3/8" and tin
5	Black	Field	16	8-7/8"	Strip 3/8" and tin
6	Yellow	Field	16	3-1/2"	Strip 3/16" for T2
7	Black	Field	16	3-1/2"	Strip 3/16" for T2

BULK LEAD WIRE - BULLETIN 58-01-0003

NOTE:

All leads must be held to $\pm 1/8"$. All lead lengths are before stripping.

TERMINAL DESCRIPTION		
Code	Part No.	Qty.
T1	23-74-0896	1
T2	22-44-0300	2

WIRING INSTRUCTIONS

TITLE

CIRCULAR SAW

BULLETIN

MILWAUKEE ELECTRIC TOOL CORP. 13135 WEST LISBON RD. BROOKFIELD, WIS.

DATE

NOTE:

When installing the 23-66-0177 switch, avoid routing the wires directly over the switch screw heads. It is recommended to use an insulating sleeve over the wires if possible. Watch for pinched wires when reassembling the tool.

**SEE REVERSE SIDE
FOR TOOLS WITH
ALTERNATIVE SWITCH
CONFIGURATION**

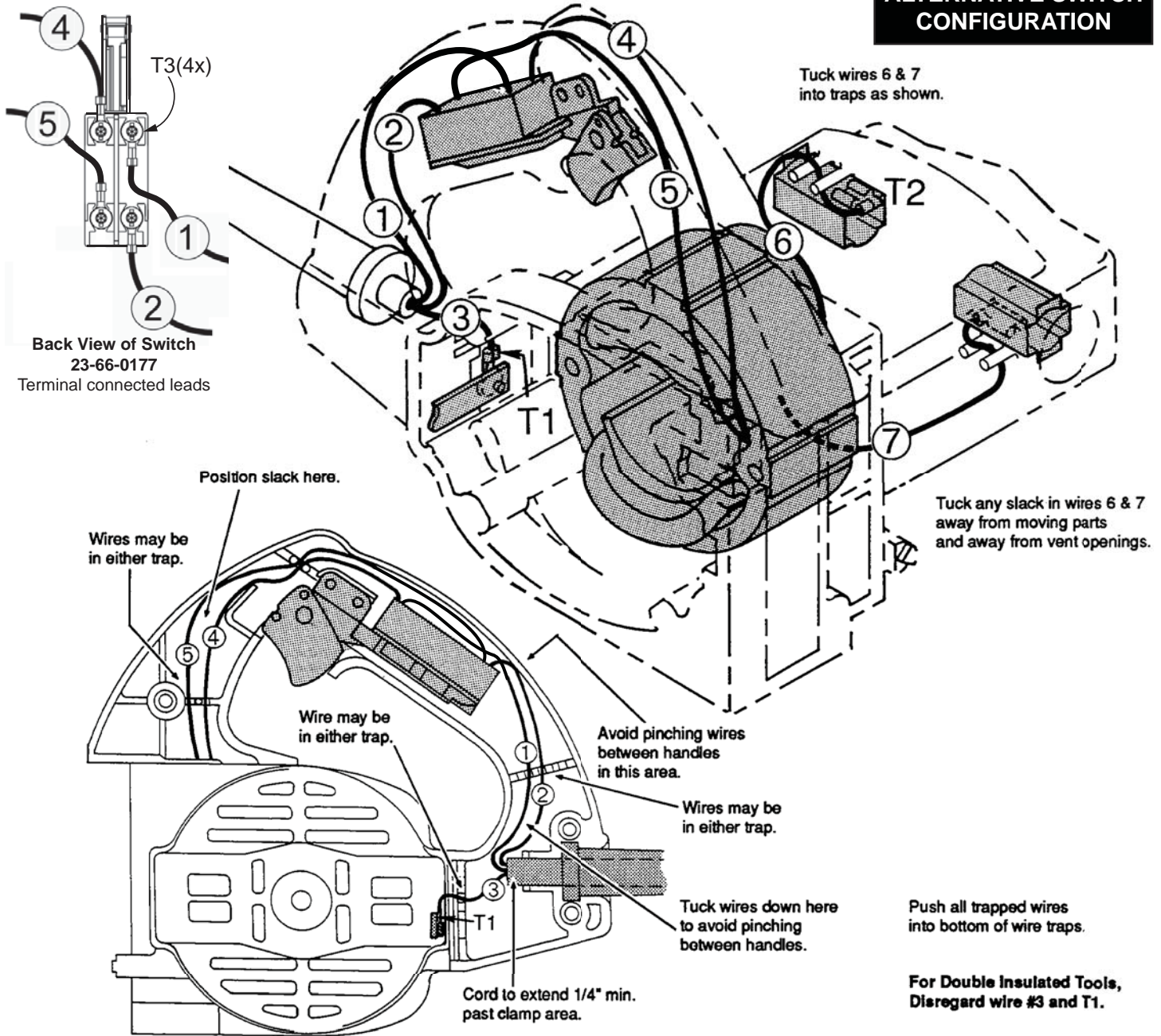

WIRING SPECIFICATIONS

Wire No.	Wire Color	Origin or Part No.	Gauge	Length	Terminals, Connectors and End Wire Preparation
1	White	Cord	16	5"	Strip 3/16" for T3
2	Black	Cord	16	5"	Strip 3/16" for T3
3	Green	Cord	16	2-1/4"	Strip 3/16" for T1
4	Yellow	Field	16	8-7/8"	Strip 3/16" for T3
5	Black	Field	16	8-7/8"	Strip 3/16" for T3
6	Yellow	Field	16	3-1/2"	Strip 3/16" for T2
7	Black	Field	16	3-1/2"	Strip 3/16" for T2

BULK LEAD WIRE - BULLETIN 58-01-0003

NOTE:

All leads must be held to ± 1/8". All lead lengths are before stripping.

TERMINAL DESCRIPTION

Code	Part No.	Qty.
T1	23-74-0896	1
T2	22-44-0300	2
T3	23-74-0850	4