

Milwaukee[®]

**OPERATOR'S
MANUAL**

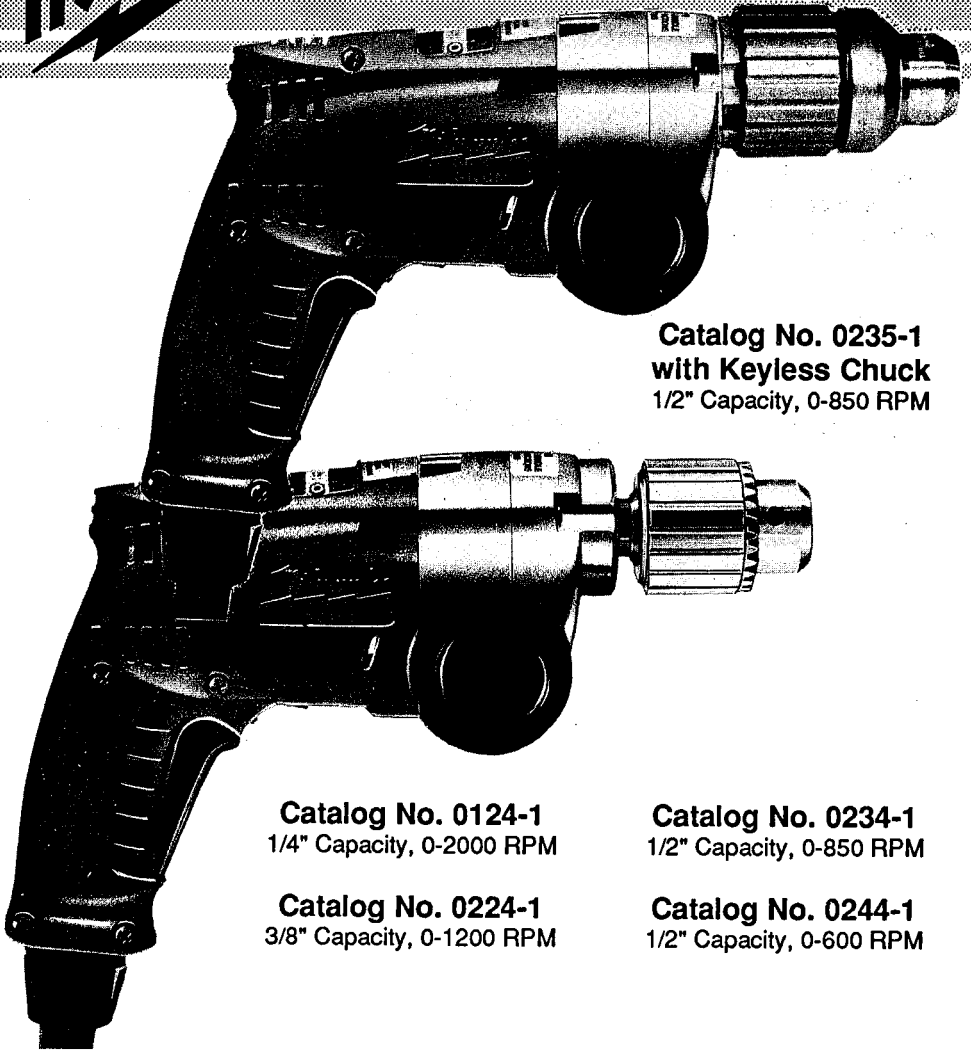

Catalog No. 0235-1
with Keyless Chuck
1/2" Capacity, 0-850 RPM

Catalog No. 0124-1
1/4" Capacity, 0-2000 RPM

Catalog No. 0234-1
1/2" Capacity, 0-850 RPM

Catalog No. 0224-1
3/8" Capacity, 0-1200 RPM

Catalog No. 0244-1
1/2" Capacity, 0-600 RPM

**HEAVY-DUTY
MAGNUM[®] HOLE-SHOOTERS**

BEFORE USE, BE SURE EVERYONE USING THIS TOOL READS AND UNDERSTANDS THIS MANUAL.

Record the following information:

Catalog No. _____ Serial No. _____ Date Purchased _____

MILWAUKEE MAGNUM® HOLE-SHOOTERS

Built for heavy-duty industrial and construction applications, *MILWAUKEE* Magnum® Hole-Shooters feature heavy-duty industrial chucks, powerful *MILWAUKEE* built motors and trigger speed control reversing switches. The exclusive Brush Cartridge System allows you to change brushes in less than one minute. In addition, the Quik-Lok cord set can be removed from the tool for quick, on site replacement. Catalog No. 0235-1 also features a keyless chuck with a ratchet mechanism driving all three jaws for a powerful grip.

Standard Equipment

Catalog Nos. 0124-1, 0224-1, 0234-1 and 0244-1: 8' Quik-Lok cord, side handle, chuck key and rubber flex key holder.

Catalog No. 0235-1: 8' Quik-Lok cord and side handle.

THIS SYMBOL ...



... IS YOUR ASSURANCE

that every tool manufactured by *MILWAUKEE* is fully inspected and produced in accordance with applicable standards for safety established by OSHA, Underwriters Laboratories, Inc., the Canadian Standards Association and the American National Standards Institute (ANSI). *MILWAUKEE* Heavy-Duty Tools bearing the monograms of Underwriters' Laboratories, Inc. or the Canadian Standards Association are listed by their testing laboratories as having complied with their standards for safety. Compliance is assured by continuing, independent inspections by both agencies.

Milwaukee Electric Tool Corporation assumes no responsibility for any damage or accidents resulting from the misuse of this tool, its misapplication or nonadherence to precautionary safety measures.

CONTENTS

Safety	3	Keyed Chucks	8
Grounding	5	Operation	9
Extension Cords	6	Keyless Chucks	10
Specifications	6	Applications	12
<i>MILWAUKEE</i> Magnum®		Maintenance	14
Hole-Shooters	7	Accessories	16
Assembly	7		

SAFETY

WARNING!

When using electric tools, always follow basic safety precautions to reduce the risk of fire, electric shock and personal injury.

READ AND SAVE ALL INSTRUCTIONS FOR FUTURE USE. Before use, be sure everyone using this tool reads and understands this manual as well as any labels packaged with or attached to the tool.

- 1. KNOW YOUR POWER TOOL.** Read this manual carefully to learn your power tool's applications and limitations as well as potential hazards associated with this type of tool.
- 2. GROUND YOUR TOOL** unless your tool is Double Insulated. See "Grounding".
- 3. AVOID DANGEROUS ENVIRONMENTS.** Do not use your power tool in rain, damp or wet locations or in the presence of explosive atmospheres (gaseous fumes, dust or flammable materials). Remove materials or debris that may be ignited by sparks.
- 4. KEEP WORK AREA CLEAN AND WELL LIT.** Cluttered, dark work areas invite accidents.
- 5. DRESS PROPERLY.** Do not wear loose clothing or jewelry. Wear a protective hair covering to contain long hair. These may be caught in moving parts. When working outdoors, wear rubber gloves and insulated non-skid footwear. Keep hands and gloves away from moving parts.
- 6. USE SAFETY EQUIPMENT.** Everyone in the work area should wear safety goggles or glasses with side shields complying with current safety standards. Wear hearing protection during extended use and a dust mask for dusty operations. Hard hats, face shields, safety shoes, etc. should be used when specified or necessary. Keep a fire extinguisher nearby.
- 7. KEEP BYSTANDERS AWAY.** Children and bystanders should be kept at a safe distance from the work area to avoid distracting the operator and contacting the tool or extension cord.
- 8. PROTECT OTHERS IN WORK AREA** from debris such as chips and sparks. Provide barriers or shields as needed.
- 9. SECURE WORK.** Use a clamp, vise or other practical means to hold your work securely, freeing both hands to control the tool.
- 10. USE THE RIGHT TOOL.** Do not use a tool or attachment to do a job for which it is not recommended. For example, do not use a circular saw to cut tree limbs or logs. Do not alter a tool.
- 11. USE PROPER ACCESSORIES.** Using unrecommended accessories may be hazardous. Be sure accessories are properly installed and maintained. Do not defeat a guard or other safety device when installing an accessory or attachment.
- 12. CHECK FOR DAMAGED PARTS.** Inspect guards and other parts before use. Check for misalignment, binding of moving parts, improper mounting, broken parts and any other conditions

that may effect operation. If abnormal noise or vibration occurs, turn the tool off immediately and have the problem corrected before further use. Do not use a damaged tool. Tag damaged tools "DO NOT USE" until repaired. A guard or other damaged part should be properly repaired or replaced by a *MILWAUKEE* service facility. For all repairs, insist on only identical replacement parts.

13. **REMOVE ALL ADJUSTING KEYS AND WRENCHES.** Make a habit of checking that adjusting keys, wrenches, etc. are removed from the tool before turning it on.

14. **GUARD AGAINST ELECTRIC SHOCK.** Prevent body contact with grounded surfaces such as pipes, radiators, ranges and refrigerators. **When making blind or plunge cuts, always check the work area for hidden wires or pipes.** Hold your tool by insulated nonmetal grasping surfaces. Use a Ground Fault Circuit Interrupter (GFCI) to reduce shock hazards.

15. **AVOID ACCIDENTAL STARTING.** Be sure your tool is turned off before plugging it in. Do not use a tool if the power switch does not turn the tool on and off. Do not carry a plugged-in tool with your finger on the switch.

16. **DO NOT FORCE TOOL.** Your tool will perform best at the rate for which it was designed. Excessive force only causes operator fatigue, increased wear and reduced control.

17. **KEEP HANDS AWAY FROM ALL CUTTING EDGES AND MOVING PARTS.**

18. **DO NOT ABUSE CORD.** Never carry your tool by its cord or unplug it by

yanking the cord from the outlet. Pull plug rather than cord to reduce the risk of damage. Keep the cord away from heat, oil, sharp objects, cutting edges and moving parts.

19. **DO NOT OVERREACH—MAINTAIN CONTROL.** Keep proper footing and balance at all times. Maintain a firm grip. Use extra care when using tool on ladders, roofs, scaffolds, etc.

20. **STAY ALERT.** Watch what you are doing, and use common sense. Do not use a tool when you are tired, distracted or under the influence of drugs, alcohol or any medication causing decreased control.

21. **UNPLUG TOOL** when it is not in use, before changing accessories or performing recommended maintenance.

22. **MAINTAIN TOOLS CAREFULLY.** Keep handles dry, clean and free from oil and grease. Keep cutting edges sharp and clean. Follow instructions for lubricating and changing accessories. Periodically inspect tool cord and extension cords for damage. Have damaged parts repaired or replaced by a *MILWAUKEE* service facility.

23. **MAINTAIN LABELS & NAME-PLATES.** These carry important information. If unreadable or missing, contact a *MILWAUKEE* service facility for a free replacement.

24. **STORE IDLE TOOLS.** When not in use, store your tool in a dry, secured place. Keep out of reach of children.

25. **USE SIDE HANDLE** for better control and safety.

GROUNDING

Grounded Tools: Tools with Three Prong Plugs

Tools marked "Grounding Required" have a three wire cord and three prong grounding plug. The plug must be connected to a properly grounded outlet (see Figure A). If the tool should electrically malfunction or breakdown, grounding provides a low resistance path to carry electricity away from the user, reducing the risk of electric shock.

The grounding prong in the plug is connected through the green wire inside the cord to the grounding system in the tool. The green wire in the cord must be the only wire connected to the tool's grounding system and must never be attached to an electrically "live" terminal.

Your tool must be plugged into an appropriate outlet, properly installed and grounded in accordance with all codes and ordinances. The plug and outlet should look like those in Figure A.

Figure B illustrates a temporary adapter available for connecting grounded plugs (Figure A) to two prong outlets. The green rigid ear or lug extending from the adapter must be connected to a permanent ground such as a properly grounded outlet box or receptacle. Simply remove the center screw from the outlet, insert the adapter and re-attach the screw through the green grounding ear to the outlet. If in doubt of proper grounding, call a qualified electrician. A temporary adapter should only be used until a properly grounded outlet can be installed by a qualified electrician. The Canadian Electrical Code prohibits the use of temporary adapters.

WARNING!

Improperly connecting the grounding wire can result in the risk of electric shock. Check with a qualified electrician if you are in doubt as to whether the outlet is properly grounded. Do not modify the plug provided with the tool. *Never remove the grounding prong from the plug.* Do not use the tool if the cord or plug is damaged. If damaged, have it repaired by a MILWAUKEE service facility before use. If the plug will not fit the outlet, have a proper outlet installed by a qualified electrician.

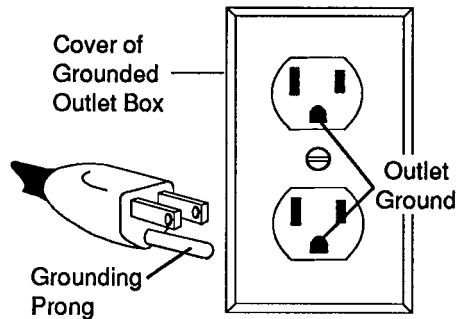

Fig. A

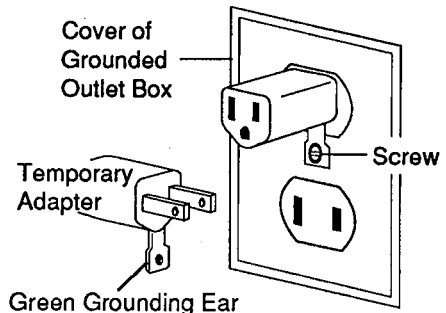

Fig. B

EXTENSION CORDS

Grounded tools require a three wire extension cord. Double insulated tools can use either a two or three wire extension cord. As the distance from the supply outlet increases, you must use a heavier gauge extension cord. Using extension cords with inadequately sized wire causes a serious drop in voltage, resulting in loss of power and possible tool damage. Refer to the table below to determine the required minimum wire size.

Recommended Minimum Wire Gauge for Extension Cords*

Nameplate Amperes	Extension Cord Length					
	25'	50'	75'	100'	150'	200'
0 - 5	16	16	16	14	12	12
5.1 - 8	16	16	14	12	10	--
8.1 - 12	14	14	12	10	--	--
12.1 - 15	12	12	10	10	--	--
15.1 - 20	10	10	10	--	--	--

*Based on limiting the line voltage drop to five volts at 150% of the rated amperes.

The smaller the gauge number of the wire, the greater the capacity of the cord. For example, a 14 gauge cord can carry a higher

current than an 16 gauge cord. When using more than one extension cord to make up the total length, be sure each cord contains at least the minimum wire size required. If you are using one extension cord for more than one tool, add the nameplate amperes and use the sum to determine the required minimum wire size.

Guidelines for Using Extension Cords

- If you are using an extension cord outdoors, be sure it is marked with the suffix "W-A" ("W" in Canada) to indicate that it is acceptable for outdoor use.
- Be sure your extension cord is properly wired and in good electrical condition. Always replace a damaged extension cord or have it repaired by a qualified person before using it.
- Protect your extension cords from sharp objects, excessive heat and damp or wet areas.

READ AND SAVE ALL INSTRUCTIONS FOR FUTURE REFERENCE.

SPECIFICATIONS

Cat. No.	No Load RPM	Wood						Steel		Masonry
		Flat Boring Bits	Auger Bits	Ship Auger Bits	Selffeed Bits	Hole Saws	Twist Drills	Twist Drills	Hole Saws	Carbide-Tipped Bits
0124-1	0-2000	1"	NR	NR	NR	1-3/4"	1/4"	1/4"	1"	3/8"
0224-1	0-1200	1-1/2"	NR	3/4"	NR	2-3/4"	3/8"	3/8"	1-3/16"	7/16"
0234-1	0-850	1-1/2"	7/8"	7/8"	1-1/8"	3-1/4"	1/2"	1/2"	1-3/8"	1/2"
0235-1	0-850	1-1/2"	7/8"	7/8"	1-1/8"	3-1/4"	1/2"	1/2"	1-3/8"	1/2"
0244-1	0-600	1-1/2"	1-1/8"	1-1/8"	1-3/8"	3-1/2"	1/2"	1/2"	1-1/2"	9/16"

NR = not recommended

MILWAUKEE MAGNUM® HOLE-SHOOTERS

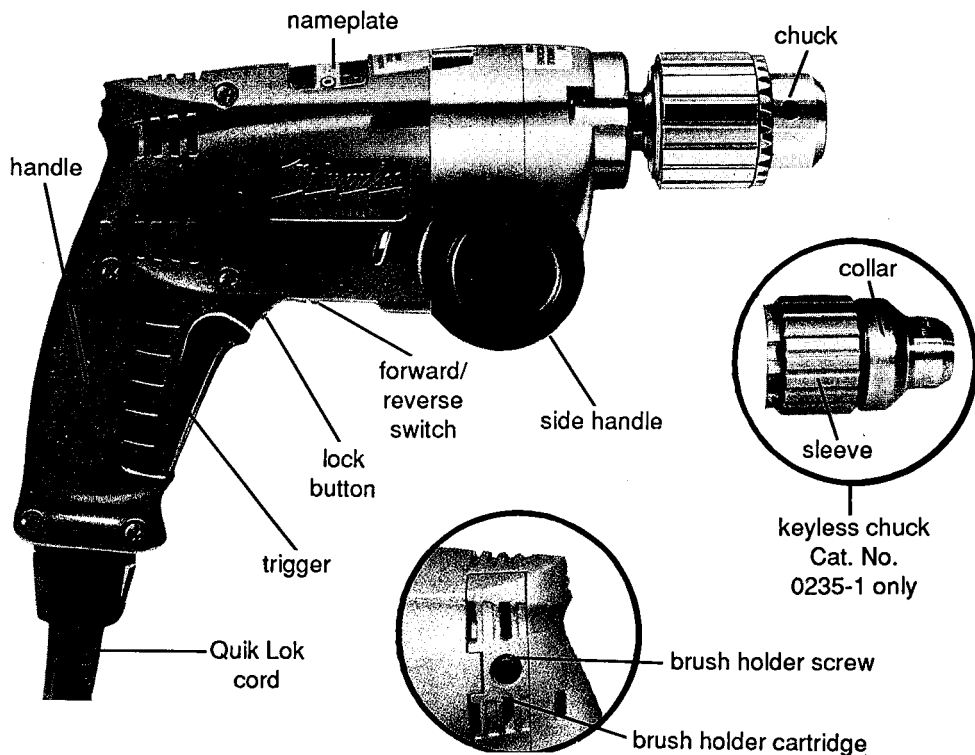

ASSEMBLY

WARNING!

To reduce the risk of injury, always unplug the tool before installing or removing accessories in keyed chucks. Only use specifically recommended accessories. Others may be hazardous.

Installing Side Handle

MILWAUKEE Magnum® Hole-Shooters are furnished with a side handle that can be installed on either side of the tool for right or left handed use. To install the side handle, thread it into the socket on the desired side of the tool and tighten it securely. Always use the side handle for best control (see page 12).

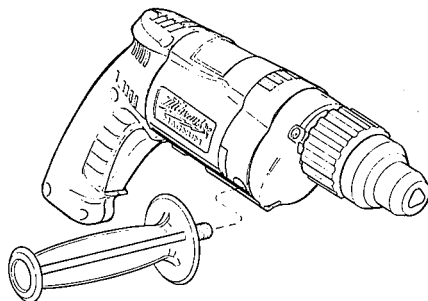

Removing and Replacing Quik-Lok Cords

MILWAUKEE's exclusive Quik-Lok Cords provide instant field replacement or substitution.

1. To remove the Quik-Lok Cord, turn the cord nut 1/4 turn to the left and pull it out.

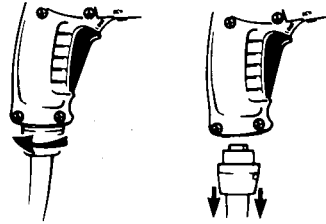

2. To replace the Quik-Lok Cord, align the connector keyways and push the connector in as far as it will go. Turn the cord nut 1/4 to the right to lock.

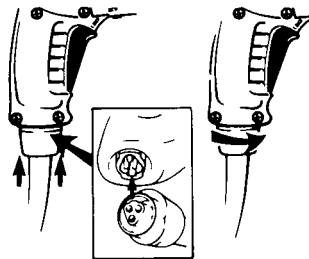

Selecting Bits

When selecting a bit, use the right type for your job. See page 6 for a list of recommended bits and capacities for various applications. For best performance, always use sharp bits.

KEYED CHUCKS

Installing Bits into Keyed Chucks

All MILWAUKEE Magnum® Hole-Shooters, except Catalog No. 0235-1, are equipped with an industrial, key-type geared chuck.

1. Open the chuck jaws wide enough to insert the bit. Be sure the bit shank and chuck jaws are clean. Dirt particles may prevent the bit from lining up properly.
2. When using drill bits, insert the bit into the chuck. Center the bit in the chuck jaws and lift it about 1/16" off of the bottom. Then, tighten the chuck jaws by hand to align the bit.

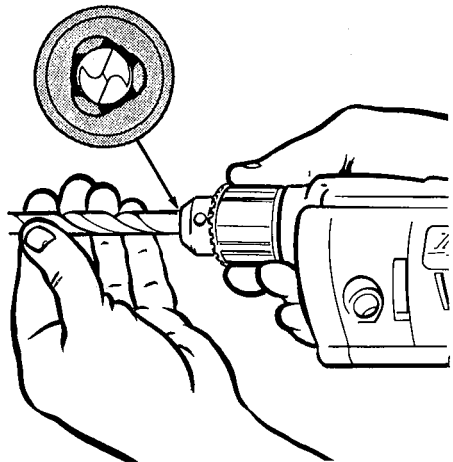

When using screwdriver bits, insert the bit far enough for the chuck jaws to grip the bit shank. Then, tighten the chuck jaws by hand to align the bit.

3. Place the chuck key in each of the three holes in the chuck, turning it clockwise as shown. Tighten securely.
4. To remove the bit, insert the chuck key into one of the holes in the chuck and turn it counterclockwise.

WARNING!
To prevent personal injury, always remove the chuck key from the chuck after each use.

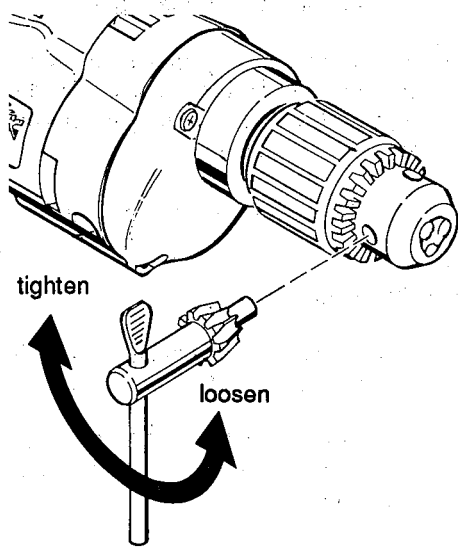

OPERATION

WARNING!
To reduce the risk of injury, keep hands and cord away from the bit and all moving parts.

Using Forward/Reverse Switch

1. For forward (clockwise) rotation, push the forward/reverse switch to FWD as shown.
2. For reverse (counterclockwise) rotation, push the forward/reverse switch to REV as shown. Although an interlock prevents reversing the tool while the motor is running, allow it to come to a full stop before reversing.

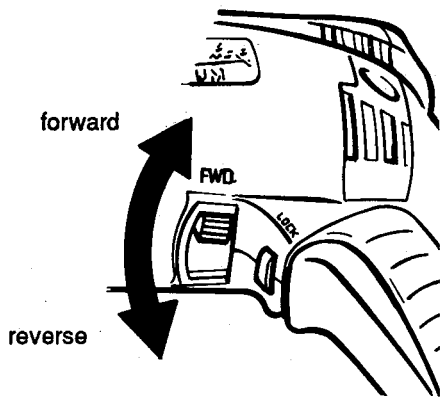

Starting, Stopping and Controlling Speed

1. To start the tool, pull the trigger.
2. To vary the driving speed, simply increase or decrease pressure on the trigger. The further the trigger is pulled, the greater the speed.
3. To stop the tool, release the trigger.

Locking Trigger

The lock button holds the trigger in the ON position for continuous full speed use.

1. To lock the trigger, hold the lock button in while pulling the trigger. Then release the trigger.
2. To unlock the trigger, pull the trigger and release. The lock button will pop out.

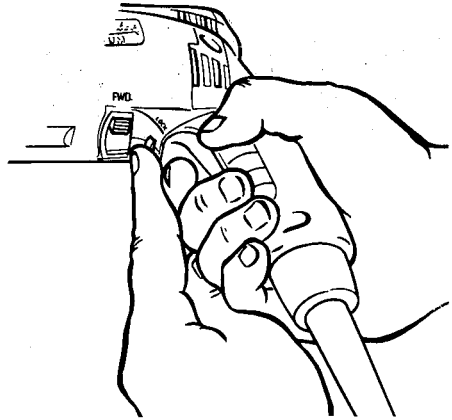

KEYLESS CHUCKS

Installing Bits into Keyless Chucks

Catalog No. 0235-1 is equipped with an industrial keyless chuck. Unlike most chucks, a key is not needed to tighten the chuck jaws. Since it is different from most types of chucks, practice using the mechanism a few times before installing a bit.

1. To install a bit, set the forward/reverse switch to FWD.
2. Insert the bit into the chuck. Center the bit in the chuck jaws and lift it about 1/16" off of the bottom. Tighten the chuck jaws by hand to align the bit as shown. Plug in the tool.

WARNING!

Do not use the tool if the variable speed trigger is damaged. Be sure the lock button is disengaged. If the variable speed is not used, the bit may be thrown from the chuck, possibly causing injury.

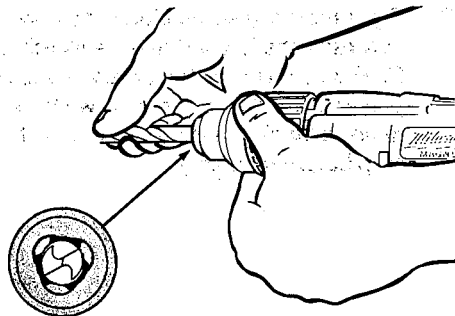

NOTE: If the chuck jaws are completely open and will not close, the impacting lugs have disengaged. The impacting lugs are designed to disengage to prevent jamming when the chuck jaws are completely open. To re-engage the impacting lugs, **remove the bit from the chuck**. Then, hold the chuck collar with your right hand while slowly running the tool in forward as shown. The impacting lugs will re-engage, allowing you to insert the bit as usual.

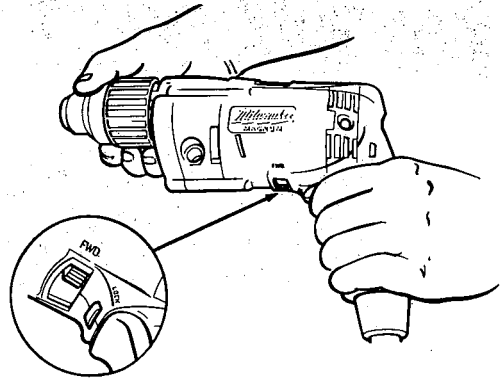

3. When the bit is centered and seated properly, hold the chuck sleeve while running the tool at full speed and ratcheting for 1 second. Repeat as necessary to increase the grip. To avoid overtightening, do not ratchet for more than 1 second at a time.

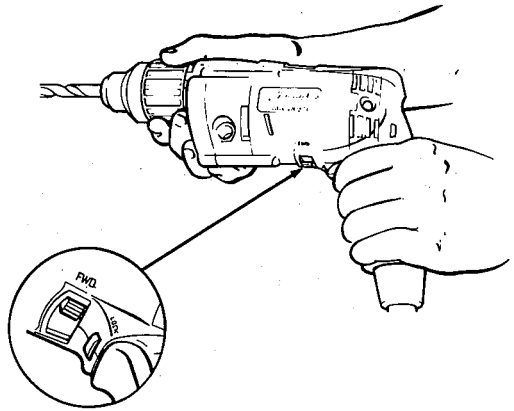

Removing Bits from Keyless Chucks

1. To remove a bit, set the forward/reverse switch to REV.
2. Point the tool down and away from you and anyone else in the area.
3. Hold the chuck sleeve while **slowly** running the tool up to full speed. Release the sleeve **as soon as the ratcheting stops**. **DO NOT HOLD THE CHUCK COLLAR.**

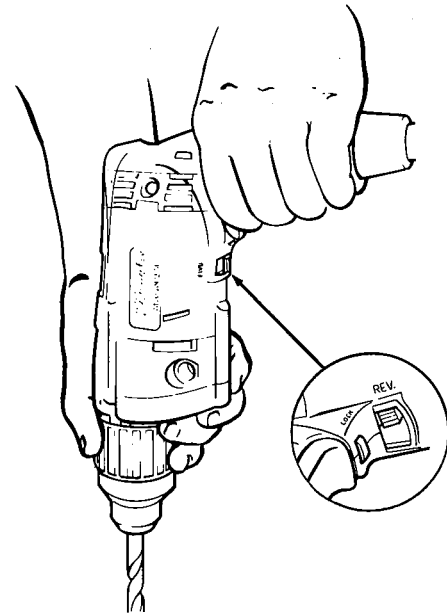

WARNING!

To reduce the risk of injury:

- Do not grasp the bit while the chuck is rotating or while the bit is falling from the chuck.
- Release the trigger as soon as the ratcheting stops to avoid throwing the bit.

APPLICATIONS

WARNING!

To reduce the risk of explosion, electric shock and property damage, always check the work area for hidden electrical wires or pipes when making blind or plunge cuts.

Drilling

1. Before drilling, be sure the workpiece is clamped securely. Use backing material to prevent damage to the workpiece during breakthrough.

WARNING!

To reduce the risk of personal injury and damage to the tool, hold and brace the tool securely. If the bit binds, the tool will be forced in the opposite direction. Bits may bind if they are misaligned or when breaking through a hole. Wood boring bits can also bind if they run into nails or knots.

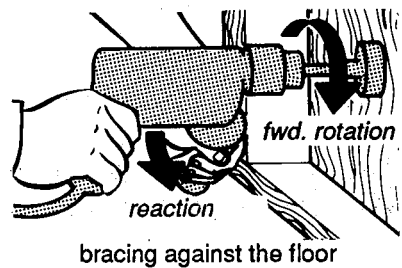
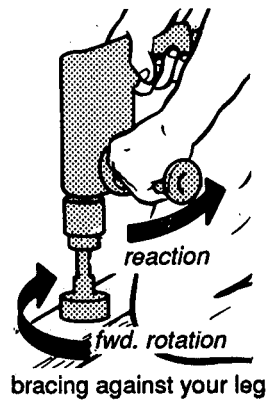
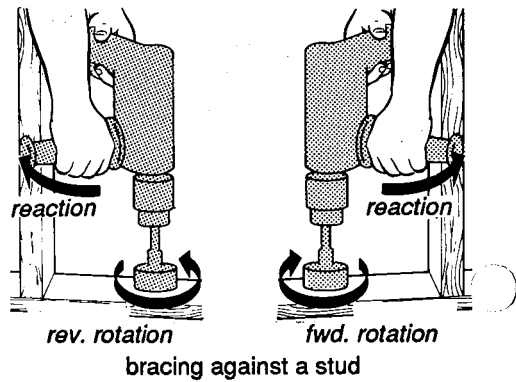

2. When starting a hole, place the drill bit on the work surface and apply firm pressure. Begin drilling at a slow speed, gradually increasing the speed as you drill.
3. Always apply pressure in line with the bit. Use enough pressure to keep the drill biting, but do not push hard enough to stall the motor.
4. Reduce pressure and ease the bit through the last part of the hole. While the tool is still running, pull the bit out of the hole to prevent jamming.

Stalling

If the tool seems as if it is about to stall, maintain a firm grip and reduce pressure slightly to allow the bit to regain speed. If the tool does stall, release the trigger immediately. Reverse the motor, remove the bit from the work and start again. Do not click the trigger on and off in an attempt to start a stalled drill. This can damage the drill.

Drilling in Wood, Composition Materials and Plastic

When drilling in wood, composition materials and plastic, start the drill slowly, gradually increasing speed as you drill. When using twist drill bits, pull the bit out of the hole frequently to clear chips from the bit flutes. Use low speeds for plastics with a low melting point.

Drilling in Metal

When drilling in metal, use high speed steel twist drills or hole saws. Use slow speeds for hard metals and high speeds for softer metals. Lubricate drill bits with cutting oil when drilling in iron or steel. Use a coolant when drilling in nonferrous metals such as copper, brass or aluminum. Back the material to prevent binding and distortion on breakthrough.

Drilling in Masonry

When drilling masonry, use high speed carbide-tipped bits at low speeds. Drilling soft masonry materials such as cinder block requires little pressure. Hard materials like concrete require more pressure. A smooth, even flow of dust indicates the proper drilling rate. Do not let the bit spin in the hole without cutting, since this will damage the bit. Do not use water to settle dust or to cool bit. This will damage the carbide and create a shock hazard.

Driving Screws

When driving screws, use the proper screwdriver bit for your job. After drilling pilot and shank holes, start the screw slowly and increase the speed as driving progresses. Set the screw by slowing to a stop. Do not run screws down at excessive speeds. If too much speed is used, the torque of the drill may twist your wrist when the screw is set. To remove screws, reverse the motor.

MAINTENANCE

WARNING!

To reduce the risk of injury, always unplug your tool before performing any maintenance. Never disassemble the tool or try to do any rewiring on the tool's electrical system. Contact a **MILWAUKEE** service facility for ALL repairs.

Replacing Brushes

MILWAUKEE Magnum® Hole-Shooters have an exclusive Brush Cartridge System. The tool will not start when the brushes are worn to 1/8", preventing expensive damage to the armature. New brushes are provided in the cartridge for fast changes anywhere.

1. To replace the brushes, unplug the tool and rest it on its side with the cartridge facing up. Loosen the brush holder screw and pull the cartridge out.
2. Remove the worn brushes. If they should fall into the tool, be sure to shake them out before reinserting the cartridge. Discard BOTH of the brushes since brushes should always be replaced in sets.
3. A set of spare brushes is provided in the cartridge. Push the brushes out of the storage compartment.
4. Position the new brushes with the flat silver end facing into the brush holder. Push the cartridge into the tool and press evenly on the top and bottom to align the terminal for proper connection.
5. Tighten the brush holder screw gently. If the head of the screw is damaged, use the replacement screw provided in the cartridge.

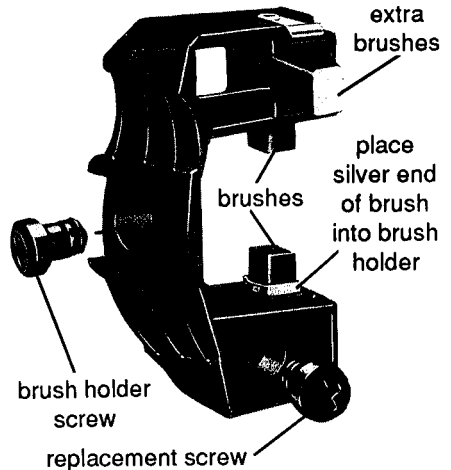

WARNING!

To reduce the risk of injury, never use a metal screw to replace the brush holder screw.

Maintaining Tools

Keep your tool in good repair by adopting a regular maintenance program. Before use, examine the general condition of your tool. Inspect guards, switches, tool cord set and extension cord for damage. Check for loose screws, misalignment, binding of moving parts, improper mounting, broken parts and any other condition that may effect its safe operation. If abnormal noise or vibration occurs, turn the tool off immediately and have the problem corrected before further use. Do not use a damaged tool. Tag damaged tools "DO NOT USE" until repaired (see "Repairs").

Under normal conditions, relubrication is not necessary until the motor brushes need to be replaced. After six months to one year, depending on use, return your tool to the nearest **MILWAUKEE** service facility for the following:

- Lubrication
- Brush inspection and replacement
- Mechanical inspection and cleaning (gears, spindles, bearings, housing, etc.)
- Electrical inspection (switch, cord, armature, etc.)
- Testing to assure proper mechanical and electrical operation

Cleaning

Clean dust and debris from vents. Keep tool handles clean, dry and free of oil or grease. Use only mild soap and a damp cloth to clean your tool since certain cleaning agents and

solvents are harmful to plastics and other insulated parts. Some of these include: gasoline, turpentine, lacquer thinner, paint thinner, chlorinated cleaning solvents, ammonia and household detergents containing ammonia. Never use flammable or combustible solvents around tools.

WARNING!

To reduce the risk of injury, electric shock and damage to the tool, never immerse your tool in liquid or allow a liquid to flow inside the tool.

Repairs

If your tool is damaged, return the entire tool to the nearest

**Milwaukee Branch Office/
Service Center,
Milwaukee Authorized
Portable Electric Tool
Service Station or**

**Milwaukee Electric Tool
Corporation
13135 West Lisbon Road
Brookfield, Wisconsin 53005
(414) 781-3600**

MILWAUKEE BRANCH OFFICES/SERVICE CENTERS

ARIZONA

Phoenix 85004
405 E. Watkins St.
(602) 256-7210

CALIFORNIA

(Los Angeles)
Anaheim 92801
1130 N. Magnolia St.
(714) 827-3970
(213) 624-7615
(213) 860-0349

(San Francisco)

S. San Francisco 94080
179 Utah Ave.
(415) 583-8484
S.F. (415) 761-2851

COLORADO

Denver 80219
2650 West 2nd Ave.
(303) 922-1163

FLORIDA

Miami 33122
8101 N.W. 33rd St.
(305) 592-0442

GEORGIA

(Atlanta)
Chamblee 30341
2381 John Glenn Dr.
(404) 455-7300

ILLINOIS

(Chicago)
Niles 60648
5629 Howard St.
Chicago (708) 539-9173
Niles (708) 647-8407

LOUISIANA

(New Orleans)
Harahan 70123
5610 Jefferson Hwy.
(504) 733-8543

MASSACHUSETTS

(Boston)
Newton 02158
143 California St.
(617) 244-4483

MICHIGAN

(Detroit)
Auburn Hills 48057
1120 Doris Road
(313) 373-3800

MINNESOTA

(Minneapolis)
Bloomington 55435
4350 W. 78th St.
(612) 835-4910

MISSOURI

Kansas City 64120
1506 N. Topping
(816) 241-7300

NEW YORK

(New York)
Woodside 11377
27-07 Brooklyn-Queens
Expressway West
N.Y. (718) 721-5151
N.J. (201) 622-7752

OHIO

(Cincinnati)
Sharonville 45241
11909 Tramway Dr.
(513) 733-3334

Cleveland 44125

7600 Wall St.
(216) 524-8040

PENNSYLVANIA

(Philadelphia)
Broomall 19008
388 Reed Road
(215) 544-5544

TEXAS

Dallas 75247
400 W. Mockingbird Ln.
(214) 637-4820

Houston 77007

4801 Katy Freeway
(713) 861-4671

WASHINGTON

Seattle 98108
5419 Maynard Ave., So.
(206) 762-8430

WISCONSIN

(Milwaukee)
Brookfield 53005
4057 N. 128th St.
(414) 781-0951

In addition, there is a nationwide network of distributors and authorized service stations ready to assist you. Check your "Yellow Pages" under "Tools-Electric" for the names of those nearest you.

WARRANTY

Every **MILWAUKEE** tool is thoroughly inspected and tested before leaving our manufacturing facilities. Should any trouble develop, return the complete tool prepaid to our Corporate Office, Branch Office/Service Center or nearest Authorized **MILWAUKEE** Service Station. If inspection shows the trouble is caused by defective workmanship or material, all repairs will be made without charge, and the tool will be returned, transportation prepaid. Battery packs for cordless tools are warranted for one year from the date of purchase.

This warranty does not apply where: (1) repairs or attempted repairs have been made by persons other than **MILWAUKEE** personnel or Authorized Service Station personnel; (2) repairs are required because of normal wear; (3) the tool has been abused or involved in an accident; (4) misuse is evident, such as caused by overloading the tool beyond its rated capacity; (5) the tool has been used after partial failure or (6) the tool has been used with an improper accessory. No other warranty, written or verbal, is authorized.

MILWAUKEE ELECTRIC TOOL CORPORATION

13135 West Lisbon Road • Brookfield, Wisconsin 53005