



SERVICE PARTS LIST

BULLETIN NO.
PN0013331

SPECIFY CATALOG NO. AND SERIAL NO. WHEN ORDERING PARTS		REVISED BULLETIN	DATE
Rechargeable Flat Flashlight w/ Green Laser			Jan. 2026
CATALOG NO. 2016R	SERIAL NO. S01A	WIRING INSTRUCTION	
NAMEPLATE SPECIFICATIONS: INPUT:5 V = 1A Contains 6.475 Wh Li-Ion CAN ICES-3(B)/NMB-3(B)			

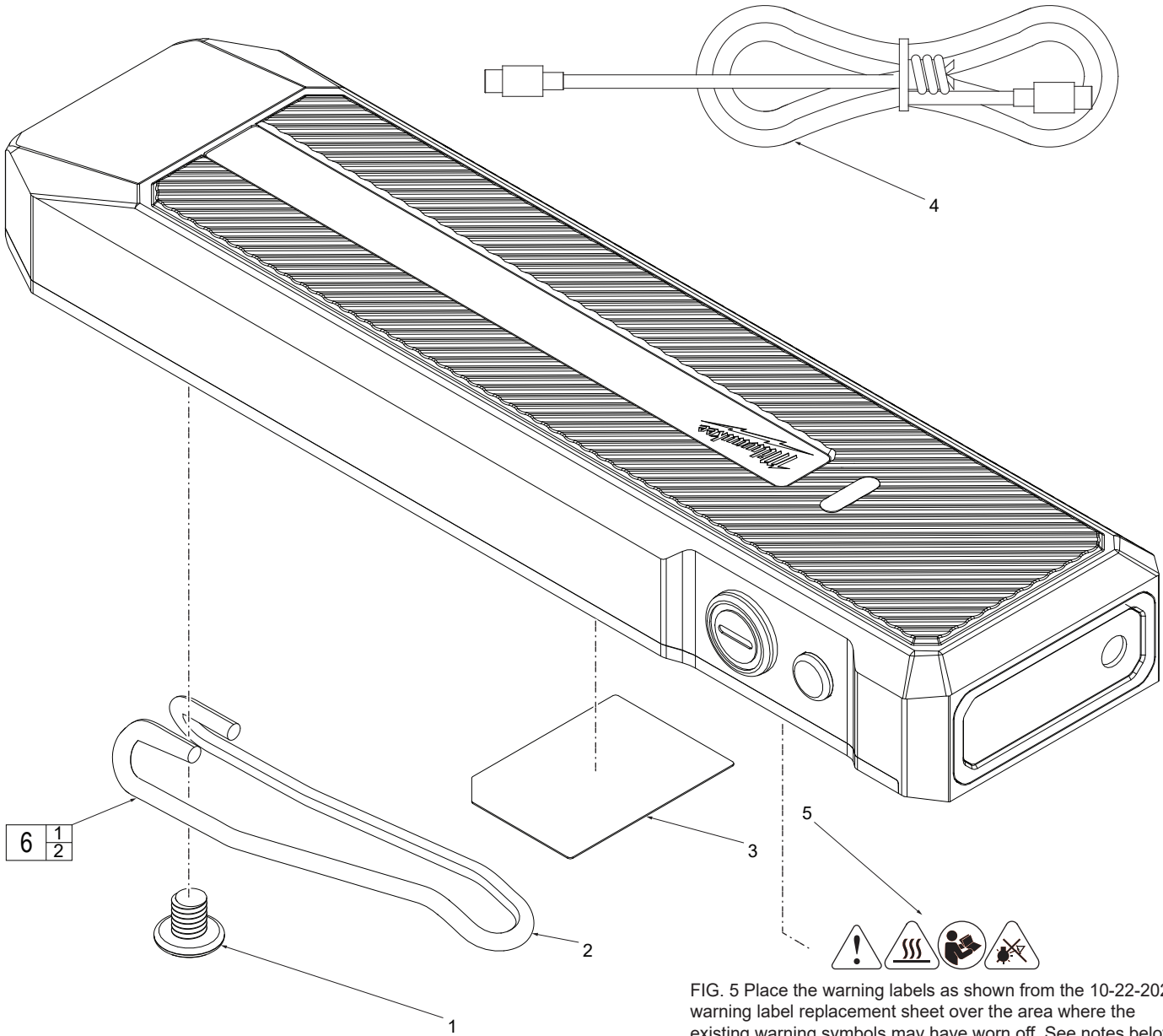

FIG.	PART NO.	DESCRIPTION OF PART	NO. REQ.
1	-----	M3.5 x 4mm Screw	(1)
2	-----	Belt Clip	(1)
3	12-20-2019	Service Nameplate	(1)
4	42-44-1211	USB-C to USB-C 2' Cable (Optional)	(1)
5	10-22-2020	Warning Label Replacement Sheet (see instructions above)	(1)
6	14-46-9119	Belt Clip Kit	(1)

SCREW TORQUE SPECIFICATIONS				
FIG.	PART NO.	WHERE USED	SEAT TORQUE	
			kgf-cm	lb-in
1	-----	Belt Clip	5-7	4-6

FIG. 5 Place the warning labels as shown from the 10-22-2020 warning label replacement sheet over the area where the existing warning symbols may have worn off. See notes below for pre-application instructions. (Label sheet may have extra icons that won't be applicable and can be discarded.)

FIG. 3, 5 NOTES
A clean, dry surface is essential for proper performance for any adhesive system. The area intended for application of any adhesive label or nameplate must be prepared by cleaning with isopropyl alcohol. The solvent is to be applied with a clean, lint free applicator and the surface allowed to dry before applying the label or nameplate.